

OPERATION AND PARTS MANUAL



MODELS **CV1A** **CV2A/2B** **CV3A/3B** **VIBRATOR MOTOR**

Revision #2 (05/20/21)

To find the latest revision of this
publication, visit our website at:
www.multiquip.com



THIS MANUAL MUST ACCOMPANY THE EQUIPMENT AT ALL TIMES.

SILICOSIS/RESPIRATORY WARNINGS

WARNING



SILICOSIS WARNING

Grinding/cutting/drilling of masonry, concrete, metal and other materials with silica in their composition may give off dust or mists containing crystalline silica. Silica is a basic component of sand, quartz, brick clay, granite and numerous other minerals and rocks. Repeated and/or substantial inhalation of airborne crystalline silica can cause serious or fatal respiratory diseases, including silicosis. In addition, California and some other authorities have listed respirable crystalline silica as a substance known to cause cancer. When cutting such materials, always follow the respiratory precautions mentioned above.

WARNING

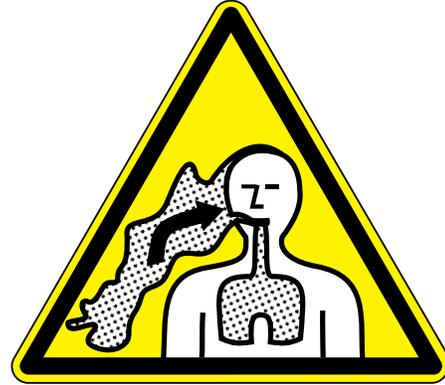

RESPIRATORY HAZARDS

Grinding/cutting/drilling of masonry, concrete, metal and other materials can generate dust, mists and fumes containing chemicals known to cause serious or fatal injury or illness, such as respiratory disease, cancer, birth defects or other reproductive harm. If you are unfamiliar with the risks associated with the particular process and/or material being cut or the composition of the tool being used, review the material safety data sheet and/or consult your employer, the material manufacturer/supplier, governmental agencies such as OSHA and NIOSH and other sources on hazardous materials. California and some other authorities, for instance, have published lists of substances known to cause cancer, reproductive toxicity, or other harmful effects.

Control dust, mist and fumes at the source where possible. In this regard use good work practices and follow the recommendations of the manufacturers or suppliers, OSHA/NIOSH, and occupational and trade associations. Water should be used for dust suppression when wet cutting is feasible. When the hazards from inhalation of dust, mists and fumes cannot be eliminated, the operator and any bystanders should always wear a respirator approved by NIOSH/MSHA for the materials being used.

TABLE OF CONTENTS

CVS Series Vibrator Motor

Silicosis/Respiratory Warnings	2
Table Of Contents	4
General Power Tool Safety Warnings	6-7
Noise And Vibration Figures	8
Safety Information	9-12
Specifications	13
Dimensions	14
General Information	15-16
Setup	17-18
Operation	19
Maintenance	20-22
Troubleshooting	23
Explanation Of Code In Remarks Column	24

Component Drawings

Decals	26-27
Vibrator Motor Housing Assembly	28-29
Vibrator Motor Assembly	30-31

NOTICE

Specifications and part numbers are subject to change without notice.

GENERAL POWER TOOL SAFETY WARNINGS

 **WARNING** Read all safety warnings and all instructions. *Failure to follow the warnings and instructions may result in electric shock, fire and/or serious injury.*

Save all warnings and instructions for future reference.

The term "power tool" in the warnings refers to your mains-operated (corded) power tool or battery-operated (cordless) power tool.

1. Work area safety

- a) **Keep work area clean and well lit.** *Cluttered or dark areas invite accidents.*
- b) **Do not operate power tools in explosive atmospheres, such as in the presence of flammable liquids, gases or dust.** *Power tools create sparks which may ignite the dust or fumes.*
- c) **Keep children and bystanders away while operating a power tool.** *Distractions can cause you to lose control.*

2. Electrical safety

- a) **Power tool plugs must match the outlet. Never modify the plug in any way. Do not use any adapter plugs with earthed (grounded) power tools.** *Unmodified plugs and matching outlets will reduce risk of electric shock.*
- b) **Avoid body contact with earthed or grounded surfaces such as pipes, radiators, ranges and refrigerators.** *There is an increased risk of electric shock if your body is earthed or grounded.*
- c) **Do not expose power tools to rain or wet conditions.** *Water entering a power tool will increase the risk of electric shock.*
- d) **Do not abuse the cord. Never use the cord for carrying, pulling or unplugging the power tool. Keep cord away from heat, oil, sharp edges or moving parts.** *Damaged or entangled cords increase the risk of electric shock.*
- e) **When operating a power tool outdoors, use an extension cord suitable for outdoor use.** *Use of a cord suitable for outdoor use reduces the risk of electric shock.*
- f) **If operating a power tool in a damp location is unavoidable, use a residual current device (RCD), or Ground fault circuit interrupter (GFCI) protected supply.** *Use of an RCD or GFCI reduces the risk of electric shock.*

3. Personal safety

- a) **Stay alert, watch what you are doing and use common sense when operating a power tool. Do not use a power tool while you are tired or under the influence of drugs, alcohol or medication.** *A moment of inattention while operating power tools may result in serious personal injury.*
- b) **Use personal protective equipment. Always wear eye protection.** *Protective equipment such as dust mask, non-skid safety shoes, hard hat, or hearing protection used for appropriate conditions will reduce personal injuries.*
- c) **Prevent unintentional starting. Ensure the switch is in the off-position before connecting to power source and/or battery pack, picking up or carrying the tool.** *Carrying power tools with your finger on the switch or energizing power tools that have the switch on invites accidents.*
- d) **Remove any adjusting key or wrench before turning the power tool on.** *A wrench or a key left attached to a rotating part of the power tool may result in personal injury.*
- e) **Do not overreach. Keep proper footing and balance at all times.** *This enables better control of the power tool in unexpected situations.*

GENERAL POWER TOOL SAFETY WARNINGS

- f) **Dress properly. Do not wear loose clothing or jewelry. Keep your hair, clothing and gloves away from moving parts.** *Loose clothes, jewelry or long hair can be caught in moving parts.*
- g) **If devices are provided for the connection of dust extraction and collection facilities, ensure these are connected and properly used.** *Use of dust collection can reduce dust-related hazards.*

4. Power tool use and care

- a) **Do not force the power tool. Use the correct power tool for your application.** *The correct power tool will do the job better and safer at the rate for which it was designed.*
- b) **Do not use the power tool if the switch does not turn it on and off.** *Any power tool that cannot be controlled with the switch is dangerous and must be repaired.*
- c) **Disconnect the plug from the power source and/or the battery pack from the power tool before making any adjustments, changing accessories, or storing power tools.** *Such preventive safety measures reduce the risk of starting the power tool accidentally.*
- d) **Store idle power tools out of the reach of children and do not allow persons unfamiliar with the power tool or these instructions to operate the power tool.** *Power tools are dangerous in the hands of untrained users.*
- e) **Maintain power tools. Check for misalignment or binding of moving parts, breakage of parts and any other condition that may affect the power tool's operation. If damaged, have the power tool repaired before use.** *Many accidents are caused by poorly maintained power tools.*
- f) **Keep cutting tools sharp and clean.** *Properly maintained cutting tools with sharp cutting edges are less likely to bind and are easier to control.*
- g) **Use the power tool, accessories and tool bits etc. in accordance with these instructions, taking into account the working conditions and the work to be performed.** *Use of the power tool for operations different from those intended could result in a hazardous situation.*

5. Service

- a) **Have your power tool serviced by a qualified repair person using only identical replacement parts.** *This will ensure that the safety of the power tool is maintained.*

NOISE AND VIBRATION FIGURES

Noise Emissions

It is recommended the operator wear hearing protection while operating the power tool.

Sound pressure level at the work station: $L_{pA} = 82.5$ dB (in accordance with EN ISO 11203)

Sound pressure level: $L_{WA} = 93.5$ dB (in accordance with EN ISO 3744)

Vibration Emissions

Vibration Emissions Value = 1.23 m/s²

Uncertainty = 1.5 m/s²

The declared vibration total value has been measured in accordance with a standard test method (EN 60745-2-12; 2009 6.2.6.3) and may be used for comparing one tool with another.

The declared vibration total value may also be used in a preliminary assessment of exposure.

Warning!

The vibration emission during actual use of the power tool can differ from the declared total value depending on the ways in which the tool is used.

Identify safety measures to protect the operator that are based on an estimation of exposure in the actual conditions of use (taking account of all parts of the operating cycle such as the times when the tool is switched off and when it is running idle in addition to the trigger time).

SAFETY INFORMATION

Do not operate or service the equipment before reading the entire manual. Safety precautions should be followed at all times when operating this equipment. Failure to read and understand the safety messages and operating instructions could result in injury to yourself and others.



SAFETY MESSAGES

The four safety messages shown below will inform you about potential hazards that could injure you or others. The safety messages specifically address the level of exposure to the operator and are preceded by one of four words: **DANGER**, **WARNING**, **CAUTION** or **NOTICE**.

SAFETY SYMBOLS

⚠ DANGER

Indicates a hazardous situation which, if not avoided, **WILL** result in **DEATH** or **SERIOUS INJURY**.

⚠ WARNING

Indicates a hazardous situation which, if not avoided, **COULD** result in **DEATH** or **SERIOUS INJURY**.

⚠ CAUTION

Indicates a hazardous situation which, if not avoided, **COULD** result in **MINOR** or **MODERATE INJURY**.

NOTICE

Addresses practices not related to personal injury.

Potential hazards associated with the operation of this equipment will be referenced with hazard symbols which may appear throughout this manual in conjunction with safety messages.

Symbol	Safety Hazard
	Burn hazards
	Electric shock hazards
IPX-4	Protected against splashing water
	Earth Ground
	To reduce risk of injury user must read instruction manual

SAFETY INFORMATION

GENERAL SAFETY

⚠ CAUTION

- **NEVER** operate this equipment without proper protective clothing, shatterproof glasses, respiratory protection, hearing protection, steel-toed boots and other protective devices required by the job or city and state regulations.



- Avoid wearing jewelry or loose fitting clothes that may snag on the controls or moving parts as this can cause serious injury.

- **NEVER** operate this equipment when not feeling well due to fatigue, illness or when under medication.



- **NEVER** operate this equipment under the influence of drugs or alcohol.



- **ALWAYS** clear the work area of any debris, tools, etc. that would constitute a hazard while the equipment is in operation.

- Keep work area well lit.

- No one other than the operator is to be in the working area when the equipment is in operation.

- **DO NOT** use the equipment for any purpose other than its intended purposes or applications.

NOTICE

- This equipment should only be operated by trained and qualified personnel 18 years of age and older.

- Whenever necessary, replace nameplate, operation and safety decals when they become difficult read.

- Manufacturer does not assume responsibility for any accident due to equipment modifications. Unauthorized equipment modification will void all warranties.

- **NEVER** use accessories or attachments that are not recommended by Multiquip for this equipment. Damage to the equipment and/or injury to user may result.

- **ALWAYS** know the location of the nearest fire extinguisher.



- **ALWAYS** know the location of the nearest first aid kit.



- **ALWAYS** know the location of the nearest phone or **keep a phone on the job site**. Also, know the phone numbers of the nearest **ambulance, doctor** and **fire department**. This information will be invaluable in the case of an emergency.



SAFETY INFORMATION

VIBRATOR MOTOR SAFETY

DANGER

- **ALWAYS** wear rubber insulated gloves and boots when holding the flexshaft during operation. The possibility of electrocution exists causing equipment damage and severe bodily harm even death!

DANGER

- If applicable, periodically check insulation resistance as referenced in maintenance section. The possibility of electrocution exists causing equipment damage and severe bodily harm even death!

WARNING

- **NEVER** attempt to run the core outside the casing assembly for any reason.

CAUTION

- **DO NOT** overreach. Keep proper footing and balance at all times.
- **DO NOT** carry plugged-in motor with finger on the switch.
- **NEVER** carry the motor by the cord. Use the carrying handle.
- **ALWAYS** check the vibrator motor for loosened hardware such as nuts and bolts before starting.
- Keep the cord from heat, oil, and sharp objects.
- **DO NOT** overload the motor. It will do a better and safer job at the rate for which it was designed.
- **DO NOT** expose vibrator motor to rain.
- **DO NOT** use vibrator motor in damp or wet locations without proper electrical circuits.
- **ALWAYS** keep clear of rotating or moving parts while operating the vibrator motor.
- **NEVER** leave the machine unattended while running..

- **ALWAYS** disconnect the motor from the power source when not in use, before servicing, and when changing flexible shafting and vibrator heads.

- Allow the vibrator motor to cool before servicing. Contact with hot components can cause serious burns.



- Before each use, **ALWAYS** check the motor to make certain that there are no damaged parts and that all parts function properly (such as switch, cord housing). If any damage or malfunctioning parts are found, have them repaired or replaced by an authorized service facility.

NOTICE

- Secure forms. Make sure the form work is well made and braced to withstand the stresses made by vibration.
- Keep vibrator motor clean for better and safer operation.
- **ALWAYS** store equipment properly when it is not being used. Equipment should be stored in a clean, dry location out of the reach of children and unauthorized personnel.
- Use only factory-authorized replacement parts.
- Store idle vibrator motor. When not in use, motor should be stored in a dry, safe storage area.

ELECTRICAL SAFETY

CAUTION

- Prevent body contact with grounded surfaces such as pipes, reinforcing bar, etc.
- When applicable, use a protection wiring device, such as a Ground Fault Circuit Interrupter, for the protection of personnel.
- Operate electric motor only at the specified voltage indicated on the nameplate.
- **DO NOT** spray water onto electric motor.
- **DO NOT** yank the cord to disconnect it from the receptacle. Grasp the plug itself to disconnect it.
- **ALWAYS** make sure the ON/OFF switch on the electric motor is in the OFF position when not in use and before inserting the power plug into an AC receptacle.

SAFETY INFORMATION

- Before plugging the motor into a power source, **ALWAYS** remove any wrenches or other tools from the motor, shaft, and head that were used for assembly.

Power Cord/Cable Safety

DANGER

- **ALWAYS** use a grounded 3-wire extension cord that has a 3-prong grounding plug, and a 3-pole receptacle that accepts the plug on the concrete vibrator motor. **DO NOT REMOVE THE GROUNDING PIN FROM THE PLUG!**

- **NEVER** let power cords or cables **lay in water**.

- **NEVER** use **damaged** or **worn** cables or cords when connecting equipment to generator. Inspect for cuts in the insulation.

- **NEVER** grab or touch a live power cord or cable with wet hands. The possibility exists of **electrical shock, electrocution or death**.

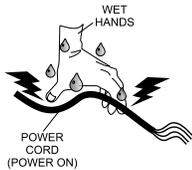

- Make sure power cables are securely connected. Incorrect connections may cause electrical shock and damage to the vibrator motor.

CAUTION

- Ensure that cables and cords will not be tripped over.

NOTICE

- **ALWAYS** make certain that proper power or extension cord has been selected for the job.
- Use only extension cords that are intended for outdoor use and so marked.

- Use only the gauge wire and length of cord recommended for the motor size. If in doubt, go to the next heavier gauge. (The smaller the gauge number, the heavier the cord.)

ENVIRONMENTAL SAFETY/DECOMMISSIONING

NOTICE

- **DO NOT** pour waste or oil directly onto the ground, down a drain or into any water source.

- Contact your country's Department of Public Works or recycling agency in your area and arrange for proper disposal of any electrical components, waste or oil associated with this equipment.

- When the life-cycle of this equipment is over it is recommended that the head casing and all other metal parts be sent to a recycling center.



SPECIFICATIONS

Table 1. Vibrator Motor Specifications					
Model#	CV1A	CV2A	CV2B	CV3A	CV3B
Horsepower	1 HP (0.746 kW)	2 HP (1.492 kW)		3 HP (2.238 kW)	
Weight	11 lbs (4989.5 g)	12.5 lbs (5669.9 g)		13.5 lbs (6123.5 g)	
RPM (No Load)	22,000 RPM				
Volts	115 VAC	115 VAC	230 VAC	115 VAC	230 VAC
Amps	10A	15 A	7.5 A	20 A	10 A
Hertz	50/60 Hz				

Table 2. Drive Motors						
Model#	Amps	Voltage/Frequency	HP (kW)	RPM	Required Shaft	Type
CV1A	10	115 VAC 50/60 Hz	1 (1.2)	16,000	FSN	Electric
CV2A	15	115 VAC 50/60 Hz	2 (1.8)	18,000	FS	Electric
CV2B	7.5	230 VAC 50/60 Hz	2 (1.8)	18,000	FS	Electric
CV3A	20	115 VAC 50/60 Hz	3 (2.4)	19,250	FS	Electric
CV3B	10	230 VAC 50/60 Hz	3 (2.4)	19,250	FS	Electric

DIMENSIONS

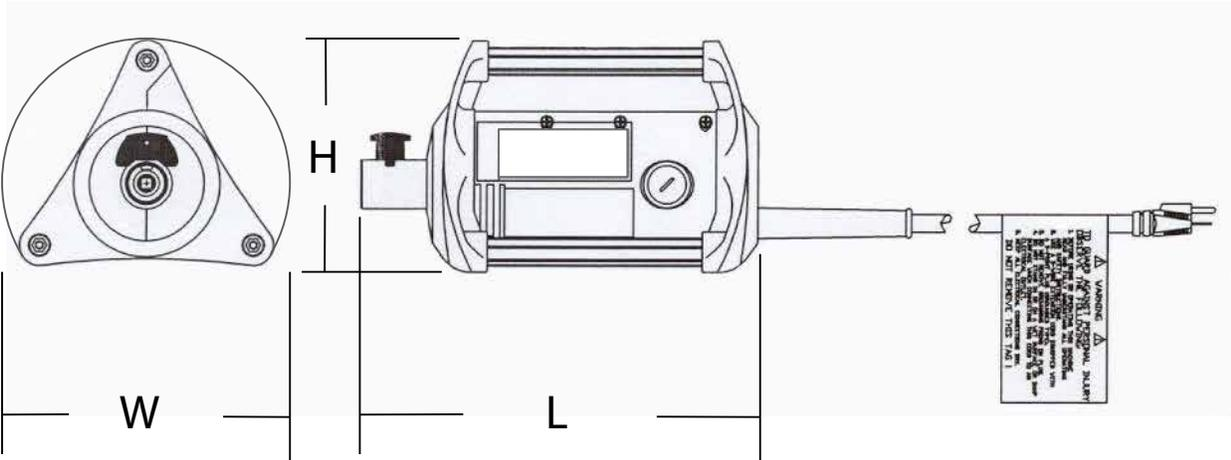

Figure 1. Dimensions

Table 3. Dimensions					
Model	CV1A	CV2A	CV2B	CV3A	CV3B
Length	13.5 inches (343 mm)	13.5 inches (343 mm)		13.5 inches (343 mm)	
Width	8.75 inches (222.25 mm)	8.75 inches (222.25 mm)		8.75 inches (222.25 mm)	
Height	7.75 inches (196.85 mm)	7.75 inches (196.85 mm)		7.75 inches (196.85 mm)	

GENERAL INFORMATION

Multiquip's CV Series Vibrator Motors are designed to work with flex shafts and vibrator heads for consolidation of fresh concrete to ensure optimum strength and durability. See Table 2 for the required shafts for the different vibrator motor models.

These vibrator motors have large vibration-isolated handles to protect the motor and the operator. They have a quick-disconnect knob for easy shaft removal.

The cassette-style motor improves durability and performance by minimizing friction and enabling the motor to maintain optimum RPM.

The flow-through ventilation feature of these motors reduces contamination by taking in air from the rear of the motor.

FLEXIBLE SHAFTS

Multiquip's flex-shafts vibrator heads are designed to work in medium to high slump concrete. Typical applications include small pours, slabs, driveways, stem walls and footings.

Typical shaft lengths range from 2 to 21 feet (0.6 to 6.4 meters). See Table 6 for recommended shaft lengths.

Steel heads, attached to one end of the flex-shaft, generate vibration via an eccentric rotator that consolidates the concrete by removing air pockets. The round head design allows for the transmission of vibration in all directions.

There are 7 different steel head sizes that range from $\frac{7}{8}$ to $2\frac{5}{8}$ inches in diameter. Typical vibration frequency for these vibrating heads range from 9,200 to 12,150 VPM with 1-inch slump when using electric motors.

CONSOLIDATION

Consolidation eliminates pockets of air bubbles maximizing strength and eliminating voids. Vibrators consolidate concrete by transmitting shock waves which allow the aggregate to float freely while pushing lighter trapped air up and out of the concrete mix.

A properly consolidated concrete pour will display a thin line of mortar appearing along the form near the vibrator and the coarse aggregate has been dispersed evenly throughout the pour and is not visible.

VIBRATION TIME

Vibration time depends on frequency. The higher the frequency, the less vibration time is required for the job.

VIBRATION RANGE

Vibration range (Figure 2) can be defined as "Area of Influence". This area of influence (vibrating radius) is the distance from the center of the vibrator to the outer most edge.

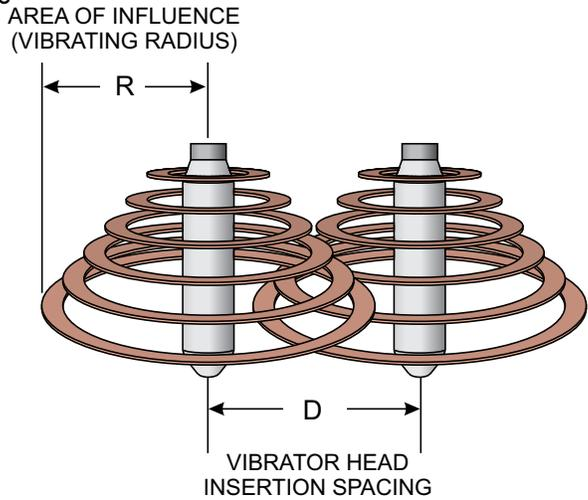

Figure 2. Vibrator Radius/Spacing

Table 4 shows the vibration radius and spacing for a given vibrator head diameter.

Table 4. Vibrating Radius/Insertion Spacing			
Vibrating HD. Model	Vibrator HD. Dia. in. (mm)#	Vibration Radius (R)	Vibrator Spacing (D)
900HD	$\frac{7}{8}$ (22)	4 (102)	6 (152)
1000HD	$1\frac{1}{16}$ (27)	5.5 (140)	8.25 (210)
1400HD	$1\frac{3}{8}$ (35)	8 (203)	12 (305)
1700HD	$1\frac{11}{16}$ (43)	12 (305)	18 (457)
2100HD	$2\frac{1}{8}$ (54)	14 (356)	21 (533)
2600HD	$2\frac{5}{8}$ (67)	18 (457)	27 (686)

NOTICE

Radius (area of influence **R**) and vibrator head spacing (**D**) are expressed in inches/millimeters. Radius and distance values expressed in Table 4 are only to be used as a general guide. Values are subject to change.

GENERAL INFORMATION

NOTICE

Vibrator head spacing distance (**D**) is calculated by multiplying the vibrating head radius (area of influence) by 1.5.

When determining which head to choose it is important to access the application; mainly the dimensions of the application. Select the vibrator head based on its radiating radius characteristics. Refer to Table 4.

Select the vibrating head that covers the largest possible area without excessive overkill. This will allow for more efficient productivity. General rule of thumb is: **DO NOT** select a vibrator head which has a vibration radius of more than twice the width of the form.

Example:

If the form width is 9 inches (229 mm) the selected vibrator head radius should not exceed an 18 inch (457 mm) radius.

In this example the 2600HD vibrator head would be the recommended choice. Refer to Table 4 and Figure 3.

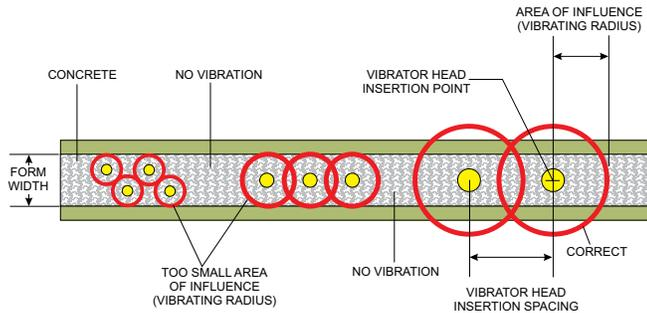

Figure 3. Head Selection

EXTENSION CORDS

When extension cords are used, refer to Table 5 for the correct size and lengths needed. Using an extension cord with a wire gauge smaller than or longer than the recommended size could result in reduced motor performance and/or damage to the motor or extension cord due to overheating.

Table 5. Extension Cord Sizes (AWG)

Ampere Rating Range	Volts		Length of Cord in Feet					
	115V	230V	25 ft.	50 ft.	100 ft.	150 ft.	200 ft.	250 ft.
	50 ft.	100 ft.	200 ft.	300 ft.	400 ft.	500 ft.		
0 - 2	18	18	18	16	16	14		
2 - 3	18	18	16	14	14	12		
3 - 4	18	18	16	14	12	12		
4 - 5	18	18	14	12	12	10		
5 - 6	18	16	14	12	10	10		
6 - 8	18	16	12	10	10	8		
8 - 10	18	14	12	10	8	8		
10 - 12	16	14	10	8	8	6		
12 - 14	16	12	10	8	6	6		
14 - 16	16	12	10	8	6	6		
16 - 18	14	12	8	8	6	4		
18 - 20	14	12	8	6	6	4		

CONNECTIONS

When connecting the vibrator motor to flex shaft and heads, use only the combination shown below in Table 6.

Table 6. Shaft Sizes			
Model	Shaft	Head	Max. Shaft Length
CV1A	FSN	900HD 1000HD	21 ft.
CV2A CV2B	FS	1400HD 1700HD	20 ft.
		2100HD	21 ft.
CV3A CV3B	FS	1400HD 1700HD 2100HD 2600HD	35 ft.

ATTACHING VIBRATING HEAD TO FLEX-SHAFT

1. Locate appropriate coupler and spindle for desired flex-shaft. See Figure 4.
2. Apply a ring of anaerobic sealant (Loctite™ No. 271) to flexshaft threads as shown in Figure 4.
3. Insert coupler and spindle into flexshaft as shown in Figure 4.
4. Attach vibrator head onto flexshaft as shown in Figure 4.
5. Use a wrench and tighten vibrator head securely to flexshaft. Threads are left-handed.

NOTICE

All flexshaft cores have been lubricated (greased) at the factory and are ready for use.

NOTICE

FS series flexshafts use a spindle that is permanently attached to the wire core.

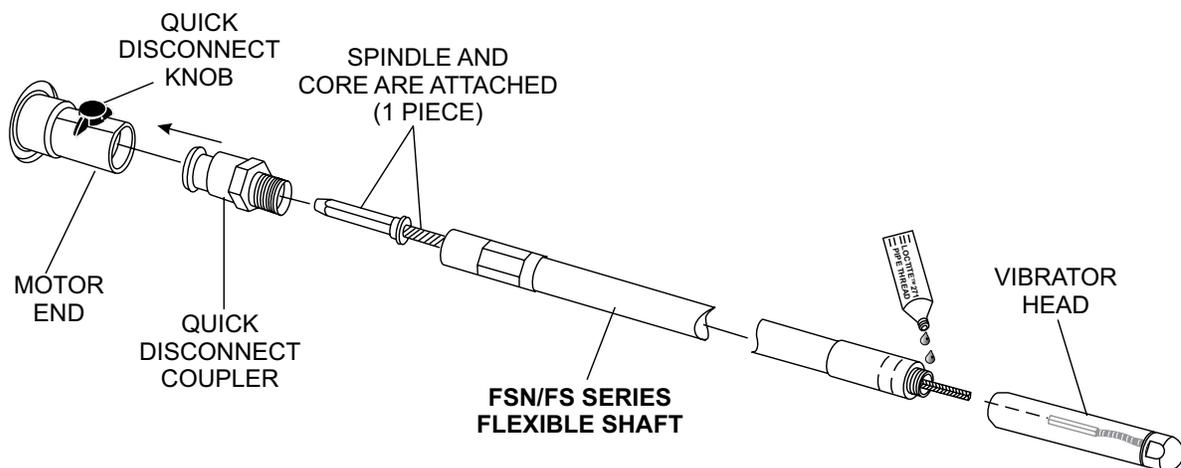

Figure 4. Attaching Vibrating Head to Flexshaft

ATTACHING FLEXSHAFT TO DRIVE MOTOR

1. Pull upward on drive motor quick-disconnect knob. Insert coupler-end of flexshaft into drive motor housing. See Figure 5.
2. Make sure flexshaft has been seated securely. Release drive motor quick-disconnect knob.

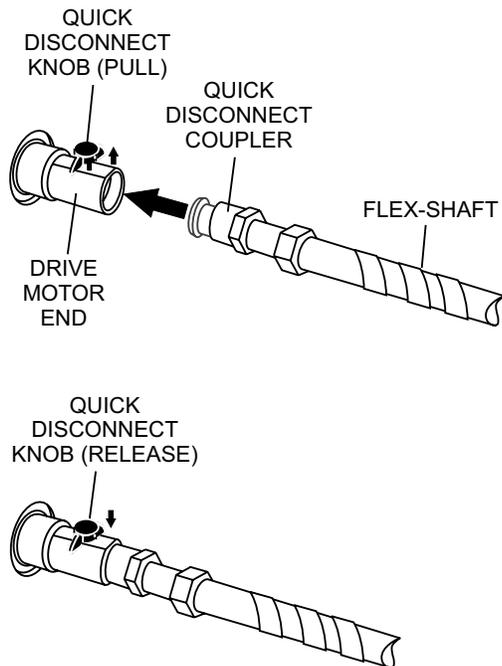

Figure 5. Connecting Flexshaft to Motor

INSTALLING FSC SHAFT COUPLER

The FSC shaft coupler allows for the extension of the FS- Series flexshafts. Maximum extension length shall not exceed 35 ft (10.6 meters).

This shaft extension coupler is only to be used on FS series shafts. **DO NOT** use the FSC shaft coupler on the FSN series flex shafts.

1. Install FSC shaft coupler as shown in Figure 6.

NOTICE

All FS-Series flexible shafts are supplied with a quick disconnect (QD) coupler. This coupler is not required for flexshaft extension.

2. Apply anaerobic sealant as required. Tighten FSC coupler securely.

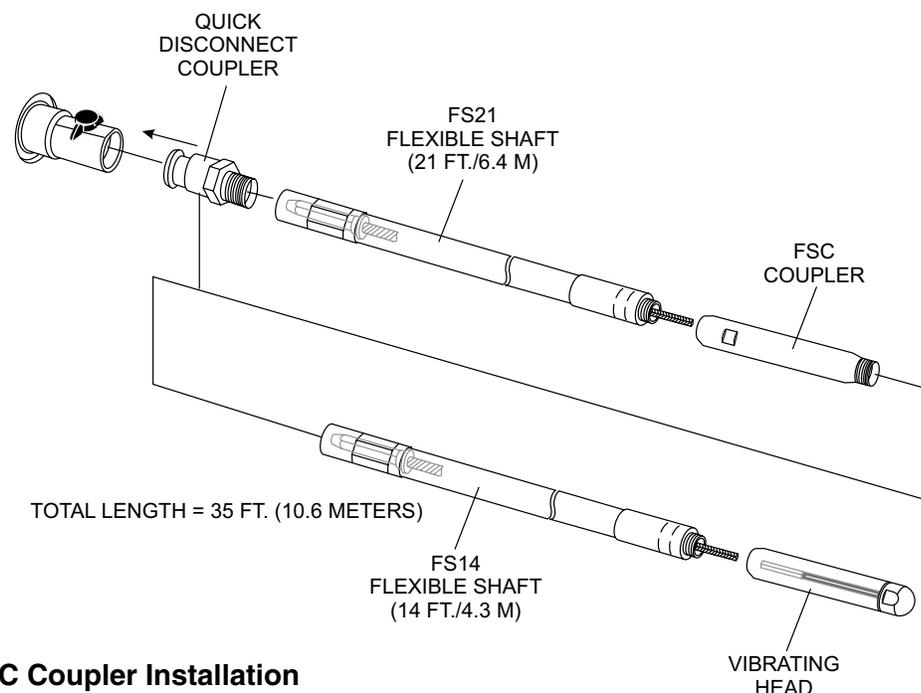

Figure 6. FSC Coupler Installation

OPERATION

Before connecting any of the flexible shafts referenced in this manual, please read all operating instructions relating to the drive motor associated with the flexshaft.

Using the wrong drive motor can adversely affect the performance of the flexshaft/vibrating head. Selecting too large a flexshaft/vibrating head combination will overload the motor and cause excessive wear.

1. Hold vibrator head above concrete pour when starting drive motor. This will prevent the vibrator head from bouncing on hard surfaces which could damage the bearings.
2. Keep flexshaft (Figure 7) straight as possible when operating. Sharp bends increase the load on the core and drive motor, which will result in early core failure and possible damage to the drive motor.

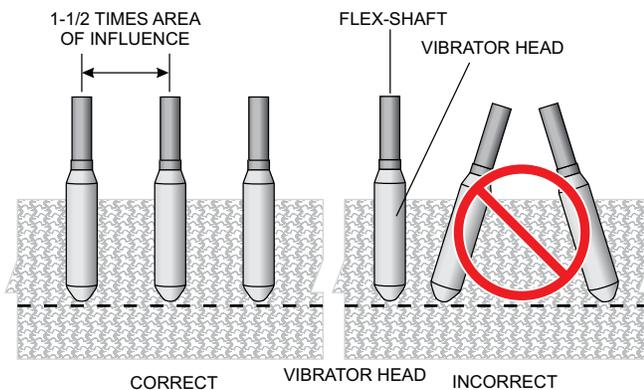

Figure 7. Vibrator Head Insertion

3. With the drive motor properly plugged into the correct power source, turn the ON/OFF switch to the "ON" position.
4. Completely immerse the vibrator head quickly into the concrete mix at a vertical rate of about one foot per second (0.3 meters/second). Vibrate concrete for about 5 to 15 seconds for wet mixes. For stiff mixes, vibrate 2-3 minutes.
5. Stop vibration of concrete mix when concrete has a level, glossy surface and there are no breaking air bubbles.

6. Slowly lift the head out of the mix using an up and down movement. This slight up and down movement will close the hole formed by the vibrator.
7. When lifting the head out of the concrete, withdraw slowly at a rate of about 3 sec./ft. Using this technique will avoid the re-trapping of air.
8. When near the top of the mix, withdraw the vibrator quickly.
9. Re-insert vibrator into mix according to the "area of influence" See Figure 7. Establish a symmetrical overlapping pattern for inserting and removing the vibrator head.
10. If concrete is poured in layers, allow vibrator to pass within 3 to 6 inches (76 to 152 mm.) into next layer to ensure the knitting of the two layers. The complete bonding of layers will prevent "lift lines" when forms are removed.

NOTICE

DO NOT use vibrator to move concrete laterally. This will cause segregation of the concrete. Use a shovel or similar device to spread the concrete.

DRIVE MOTOR MAINTENANCE

1. Visually inspect the motor daily before use for defective or missing parts, and have repairs made before use.
2. Inspect brushes frequently and replace when they become worn to a length of 3/8". See Length A in Figure 8.

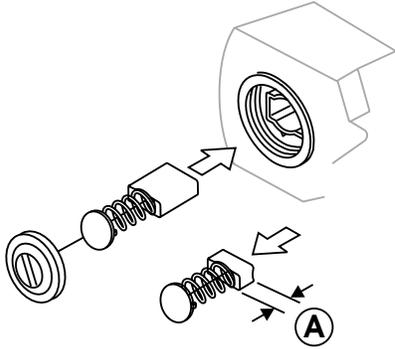

Figure 8. Brush Length

3. Keep air inlet and air exit louvers clean and free of concrete and debris. Failure to do so will result in rapid motor overheating and parts failure.
4. Clean air filter as needed. If unit is used in high dust areas, filter will have to be cleaned more often.
5. Use a screw driver to tighten brush caps. **DO NOT OVERTIGHTEN.** The brush cap must be tight enough that the brush holder does not move.'

BRONZE WEAR BUSHING REPLACEMENT

Refer to Figure 9 for location of parts.

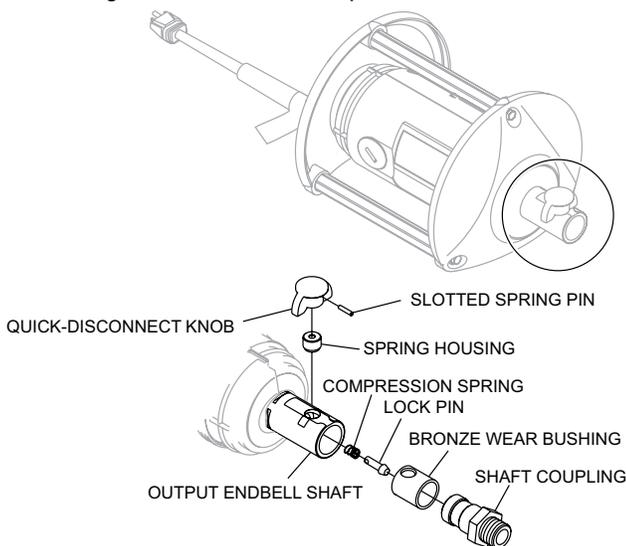

Figure 9. Bronze Wear Bushing

1. If installed, remove head assembly and shaft coupling.
2. Remove slotted spring using hammer and punch of appropriate size.
3. Once the pin is removed, the quick-disconnect knob, compression spring, and lock pin can easily be removed.

FLEXSHAFT LUBRICATION (100 HOURS)

4. Using a bench vice and wrench, remove coupler from flexshaft as shown in Figure 10. Please note threads are **right-handed** on this side of the flexshaft (drive motor end).
5. Heat should be applied to the threads to break down the anaerobic sealant. Applying heat will help prevent possible damage to threads.
6. Next, using a wrench and bench vise if necessary, remove flexible shaft from vibrator head as shown in Figure 10. Please note threads are **left-handed** on this side of the flexshaft (vibrator end).
7. Pull the wire core out from casing. Using a clean soft cloth, wipe the grease off as the wire core is pulled from the casing. Wipe clean.

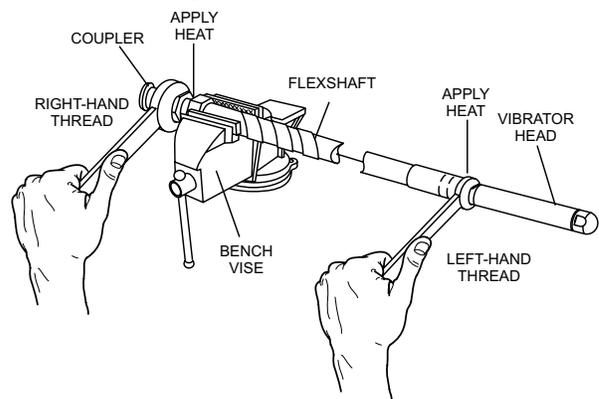

Figure 10. Removing Wire Core

8. Inspect the core for broken wires, permanent set, or other damage such as an area that indicates high wear or having overheated. If any of these conditions exists, replace wire core.

- Use the core to push a cleaning patch through the casing to remove any old grease or foreign matter that may have accumulated inside the casing.

NOTICE

DO NOT use solvents to clean casing. Applying solvents to the core or casing may cause grease (lubricant) to breakdown, resulting in damage to the flexshaft.

- Thoroughly clean wire core (Figure 11) if it is being reused. A wire brush may be required to remove hardened residue.

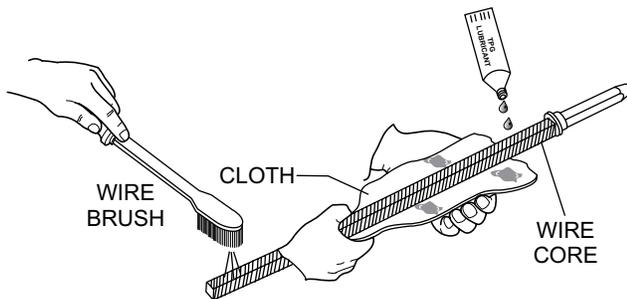

Figure 11. Cleaning Wire Core

- Apply a light amount of lubricant (Figure 11) or a good grade bearing grease to the entire length of the wire core. Lubrication recommendations are DuBois "TPG", No. 1552 Wheel Bearing Chassis Grease or No. 1551 Lithium Complex Grease

NOTICE

DO NOT force casing full of grease. A tightly packed casing will load the drive motor which could lead to overheating.

- Reinstall wire core back into casing. When re-attaching coupler and vibrator head to flexshaft, clean mating threads with an anaerobic sealant primer. Allow primer to dry for several minutes.
- Also apply a ring of anaerobic sealant (Loctite™ No. 271) to the middle of the casing ferrule threads.
- Screw the vibrator head back onto flexshaft casing. Wait one hour before using.

- Apply anaerobic sealant to coupler threads. Insert coupler back into flexshaft. Tighten securely. Wait one hour before using.

VIBRATOR HEAD LUBRICATION (300 HOURS)

- Using a wrench, remove vibrator tip (Figure 12) from vibrator head body. Have a cloth handy to catch any spilled oil.

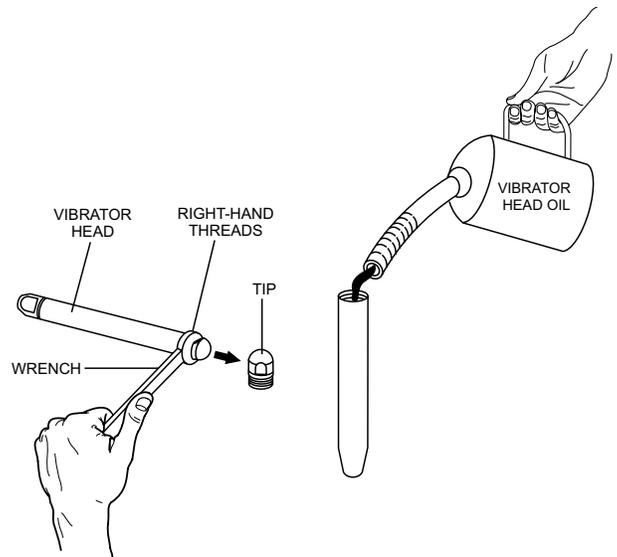

Figure 12. Adding Oil (Vibrator Head)

- Drain old oil from vibrator head body (casing). Place oil in a suitable container. **DO NOT** pour oil on the ground.

NOTICE

Dispose used vibrator head oil in accordance with city, local and state environmental guidelines.

- Fill vibrator head body with SAE 15 or AW MV ISO 46 type oil or equivalent.
- DO NOT** fill head body beyond capacity. Reference Table 7.

NOTICE

DO NOT overfill. Too much oil in the vibrator head will overload the drive motor.

Table 7. Vibrator Head Oil Capacity

Vibrating HD. Model	Oil Capacity. oz. (ml)#
900HD	0.5 (15)
1000HD	0.5 (15)
1400HD	0.5 (15)
1700HD	0.75 (22)
2100HD	1 (30)
2600HD	1.5 (44)

2. Replace vibrator head if it is not within minimum wear tolerances as specified in Table 8.

Table 8. Vibrator Head Wear Diameter

Vibrating HD. Model	Vibrator HD. New Dia. in. (mm)#	Vibrator HD. Min Wear Dia. in. (mm)
900HD	$\frac{7}{8}$ (22.22)	$\frac{13}{16}$ (20.62)
1000HD	$1\frac{1}{16}$ (26.98)	1 (25.4)
1400HD	$1\frac{3}{8}$ (34.92)	$1\frac{1}{4}$ (31.75)
1700HD	$1\frac{11}{16}$ (42.86)	$1\frac{9}{16}$ (39.67)
2100HD	$2\frac{1}{8}$ (53.97)	$1\frac{7}{8}$ (47.62)
2600HD	$2\frac{5}{8}$ (66.67)	$2\frac{1}{4}$ (57.15)

VIBRATOR HEAD WEAR (300 HOURS)

1. Periodically measure the outside diameter (Figure 13) of the vibrator head casing.

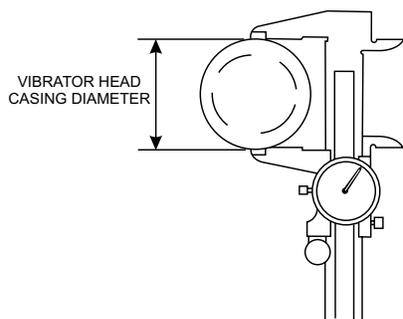

Figure 13. Vibrator Head Diameter

TROUBLESHOOTING

Table 9. Troubleshooting (Drive Motor)

Symptom	Possible Problem	Solution
Motor Does Not Start	No power to motor?	Verify unit is plugged to proper outlet. Verify extension cords are properly plugged in and are not cut or pinched. Verify power is available at outlet. Check main switch or breaker.
	Defective ON/OFF switch?	Replace switch.
Rattling Noise From Rear Of Housing Area	Rear bearing failure?	Replace bearing.
Rattling Noise From Shaft End	Worn coupler?	Disconnect coupler and turn motor on. If noise goes away, replace coupler. If noise remains, check forward bearing.
	Forward bearing failure?	Replace bearing.

Table 10. Troubleshooting (Flexshaft)

Symptom	Possible Problem	Solution
Flexshaft Binding	Flexshaft kinked?	Straighten out flexshaft.
	Defective flexshaft?	Replace flexshaft.
	Too much grease in flexshaft casing?	Relube flexshaft.
Leaking Vibrator Head	Too much oil in head casing?	Fill head casing to recommended level.
	Head bearings/seals defective?	Replace vibrator head.

EXPLANATION OF CODE IN REMARKS COLUMN

The following section explains the different symbols and remarks used in the Parts section of this manual. Use the help numbers found on the back page of the manual if there are any questions.

NOTICE

The contents and part numbers listed in the parts section are subject to change **without notice**. Multiquip does not guarantee the availability of the parts listed.

SAMPLE PARTS LIST

NO.	PART NO.	PART NAME	QTY.	REMARKS
1	12345	BOLT	1	INCLUDES ITEMS W/%
2%		WASHER, 1/4 IN.		NOT SOLD SEPARATELY
2%	12347	WASHER, 3/8 IN. ...	1	MQ-45T ONLY
3	12348	HOSE	A/R	MAKE LOCALLY
4	12349	BEARING	1	S/N 2345B AND ABOVE

NO. Column

Unique Symbols — All items with same unique symbol (@, #, +, %, or >) in the number column belong to the same assembly or kit, which is indicated by a note in the “Remarks” column.

Duplicate Item Numbers — Duplicate numbers indicate multiple part numbers, which are in effect for the same general item, such as different size saw blade guards in use or a part that has been updated on newer versions of the same machine.

NOTICE

When ordering a part that has more than one item number listed, check the remarks column for help in determining the proper part to order.

PART NO. Column

Numbers Used — Part numbers can be indicated by a number, a blank entry, or TBD.

TBD (To Be Determined) is generally used to show a part that has not been assigned a formal part number at the time of publication.

A blank entry generally indicates that the item is not sold separately or is not sold by Multiquip. Other entries will be clarified in the “Remarks” Column.

QTY. Column

Numbers Used — Item quantity can be indicated by a number, a blank entry, or A/R.

A/R (As Required) is generally used for hoses or other parts that are sold in bulk and cut to length.

A blank entry generally indicates that the item is not sold separately. Other entries will be clarified in the “Remarks” Column.

REMARKS Column

Some of the most common notes found in the “Remarks” Column are listed below. Other additional notes needed to describe the item can also be shown.

Assembly/Kit — All items on the parts list with the same unique symbol will be included when this item is purchased.

Indicated by:

“INCLUDES ITEMS W/(unique symbol)”

Serial Number Break — Used to list an effective serial number range where a particular part is used.

Indicated by:

“S/N XXXXX AND BELOW”

“S/N XXXX AND ABOVE”

“S/N XXXX TO S/N XXX”

Specific Model Number Use — Indicates that the part is used only with the specific model number or model number variant listed. It can also be used to show a part is NOT used on a specific model or model number variant.

Indicated by:

“XXXXX ONLY”

“NOT USED ON XXXX”

“Make/Obtain Locally” — Indicates that the part can be purchased at any hardware shop or made out of available items. Examples include battery cables, shims, and certain washers and nuts.

“Not Sold Separately” — Indicates that an item cannot be purchased as a separate item and is either part of an assembly/kit that can be purchased, or is not available for sale through Multiquip.

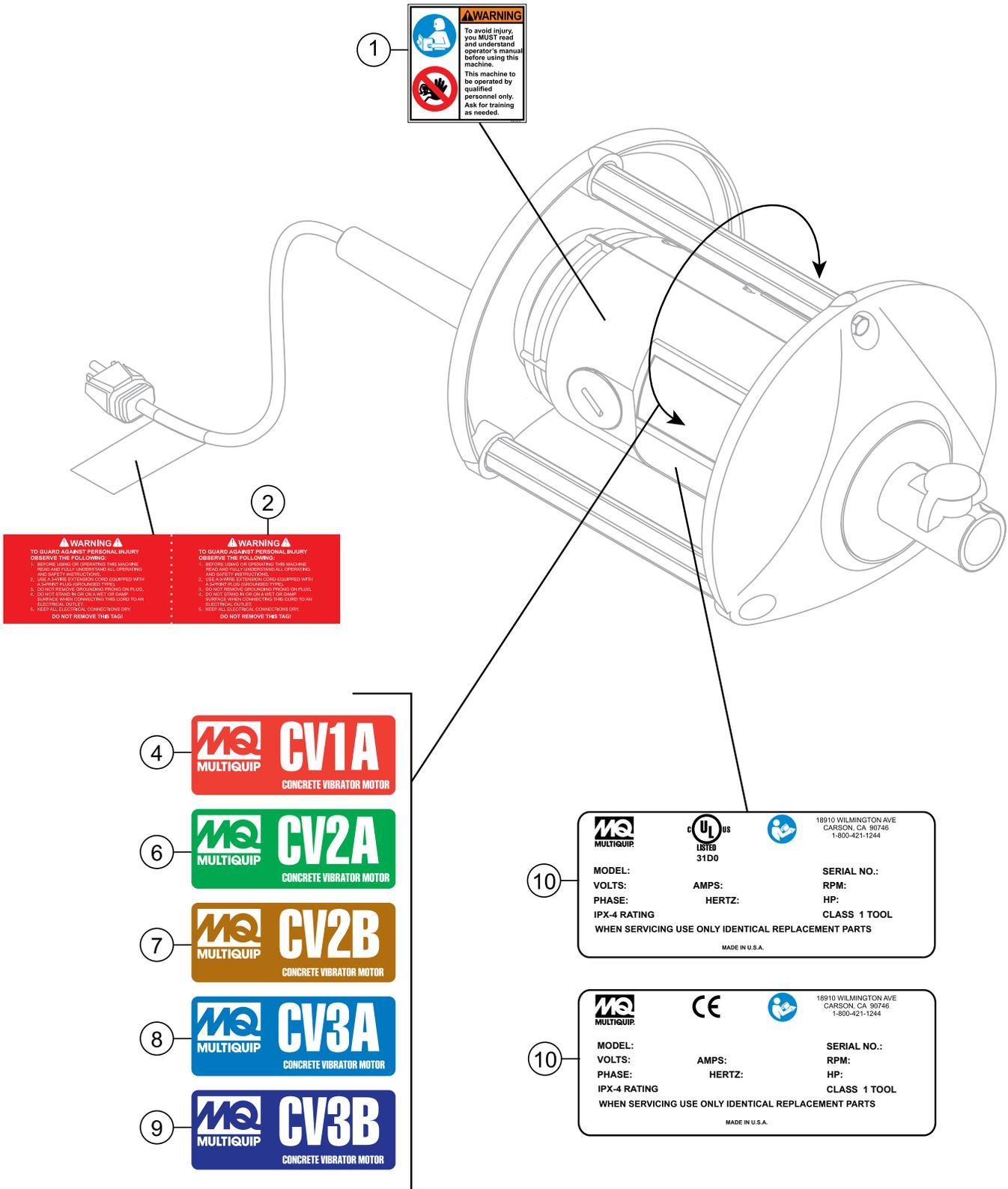

1

⚠ WARNING ⚠

To avoid injury, you **MUST** read and understand operator's manual before using this machine.

This machine to be operated by qualified personnel only. Ask for training as needed.

2

⚠ WARNING ⚠

TO GUARD AGAINST PERSONAL INJURY OBSERVE THE FOLLOWING:

- 1. BEFORE LEAVING OR OPERATING THE MACHINE
- 2. BEFORE LEAVING OR OPERATING THE MACHINE
- 3. BEFORE LEAVING OR OPERATING THE MACHINE
- 4. BEFORE LEAVING OR OPERATING THE MACHINE
- 5. BEFORE LEAVING OR OPERATING THE MACHINE
- 6. BEFORE LEAVING OR OPERATING THE MACHINE
- 7. BEFORE LEAVING OR OPERATING THE MACHINE
- 8. BEFORE LEAVING OR OPERATING THE MACHINE
- 9. BEFORE LEAVING OR OPERATING THE MACHINE
- 10. BEFORE LEAVING OR OPERATING THE MACHINE

DO NOT REMOVE THIS TAG!

4

MQ CV1A
MULTIQUIP
CONCRETE VIBRATOR MOTOR

6

MQ CV2A
MULTIQUIP
CONCRETE VIBRATOR MOTOR

7

MQ CV2B
MULTIQUIP
CONCRETE VIBRATOR MOTOR

8

MQ CV3A
MULTIQUIP
CONCRETE VIBRATOR MOTOR

9

MQ CV3B
MULTIQUIP
CONCRETE VIBRATOR MOTOR

10

MQ **UL** **US** **18910 WILMINGTON AVE**
MULTIQUIP LISTED 31D0 CARSON, CA 90746
1-800-421-1244

MODEL: SERIAL NO.:
VOLTS: AMPS: RPM:
PHASE: HERTZ: HP:
IPX-4 RATING CLASS 1 TOOL
WHEN SERVICING USE ONLY IDENTICAL REPLACEMENT PARTS

MADE IN U.S.A.

10

MQ **CE** **18910 WILMINGTON AVE**
MULTIQUIP CARSON, CA 90746
1-800-421-1244

MODEL: SERIAL NO.:
VOLTS: AMPS: RPM:
PHASE: HERTZ: HP:
IPX-4 RATING CLASS 1 TOOL
WHEN SERVICING USE ONLY IDENTICAL REPLACEMENT PARTS

MADE IN U.S.A.

DECALS

<u>NO.</u>	<u>PART NO.</u>	<u>PART NAME</u>	<u>QTY.</u>	<u>REMARKS</u>
1	00100-46	DECAL, SAFETY	1.....	SAFETY ITEM
2	00100-44	DECAL, WARNING	1.....	SAFETY ITEM
4	00100-86	DECAL, CV1A	2	
6	00100-87	DECAL, CV2A	2	
7	00100-88	DECAL, CV2B	2	
8	00100-89	DECAL, CV3A	2	
9	00100-90	DECAL, CV3B	2	
10		TAG, SERIAL NUMBER.....	1.....	CONTACT SALES DEPT.

VIBRATOR MOTOR HOUSING ASSY.

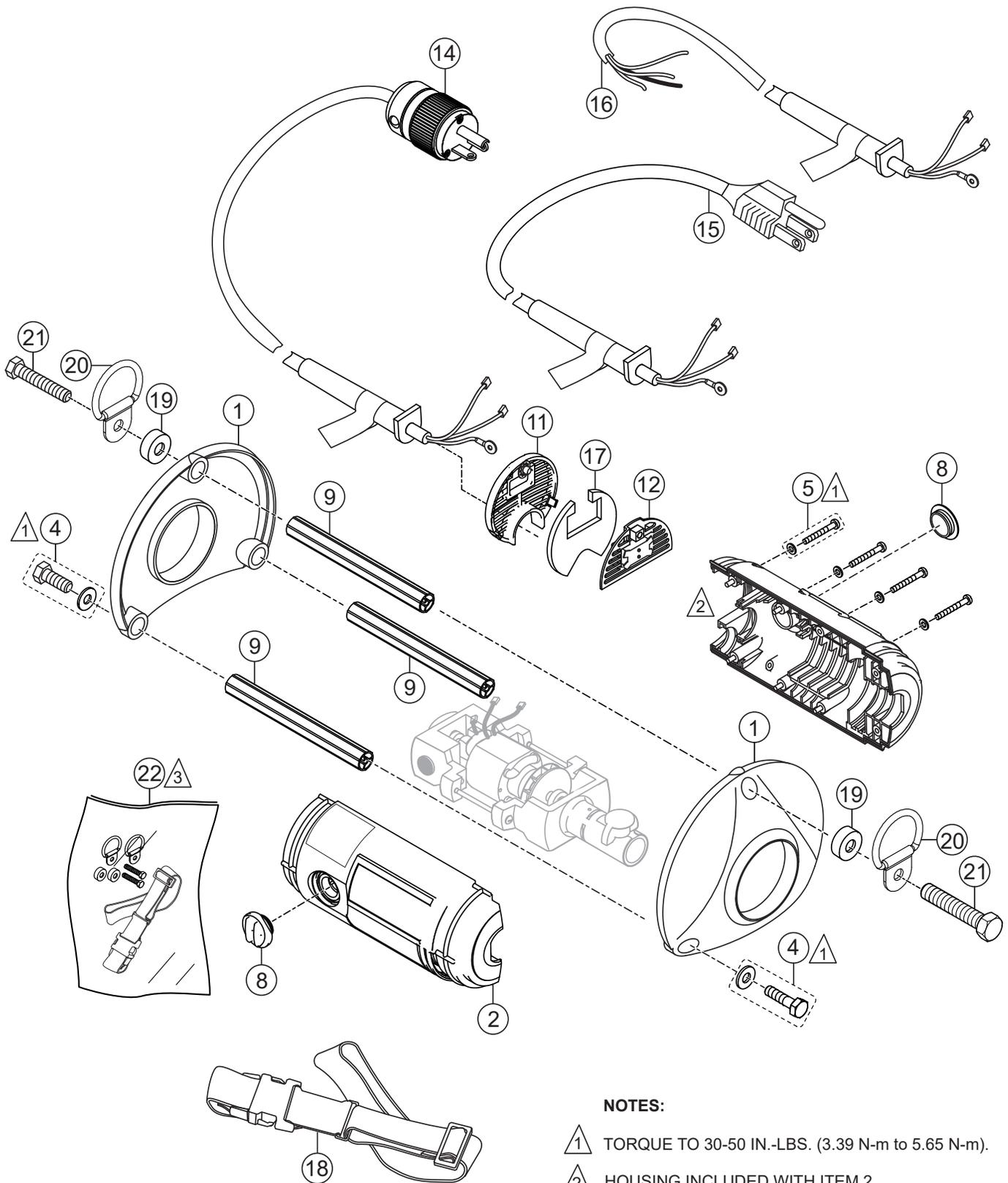

NOTES:

- ① TORQUE TO 30-50 IN.-LBS. (3.39 N-m to 5.65 N-m).
- ② HOUSING INCLUDED WITH ITEM 2.
- ③ INCLUDE ITEMS 18, 19, 20, AND 21.

VIBRATOR MOTOR HOUSING ASSY.

<u>NO.</u>	<u>PART NO.</u>	<u>PART NAME</u>	<u>QTY.</u>	<u>REMARKS</u>
1	1000-245	END CAP SET, RUBBER.....	2.....	CONTAINS 1 EA./KIT
2	1000-070	HOUSING, REPLACEMENT KIT L/R	1.....	CONTAINS 1 EA./KIT
4	1000-246	SCREW W/ WASHER KIT	4.....	CONTAINS 4 EA./KIT
5	1000-247	SCREW W/ LOCK WASHER KIT	8.....	CONTAINS 8 EA./KIT
8	1000-248	BRUSH ACCESS CAP KIT	2.....	CONTAINS 1 EA./KIT
9	1000-209	HANDLE TUBE EXTRUSION	3.....	CONTAINS 1 EA./KIT
11	8200-002	COVER, PLASTIC FILTER ASSY.	1.....	CONTAINS 1 EA./KIT
12	8200-003	SWITCH PLATE ASSY.....	1.....	CONTAINS 1 EA./KIT
14	8006-034	POWER CORD, UL, 125V 20A W/PLUG.....	1.....	CV3A
15	8006-033	POWER CORD, UL, 125V 10A W/PLUG.....	1.....	CV1A
15	8006-033	POWER CORD, UL, 125V 15A W/PLUG.....	1.....	CV2A
16	8006-035	POWER CORD, CE, 12AWG NO PLUG.....	1.....	CV3B
16	8006-035	POWER CORD, CE, 12AWG NO PLUG.....	1.....	CV2B
16	8006-035	POWER CORD, CE, 12AWG NO PLUG.....	1.....	CV2A
16	8006-035	POWER CORD, CE, 12AWG NO PLUG.....	1.....	CV1A
17	50000-03	AIR FILTER	1	
18#	CS1	CARRYING STRAP	1.....	OPTIONAL EQUIPMENT CONTACT SALES DEPT.
19#	52003-24	SPACER, 1/4"	2	
20#	50124-27	D-RING	2	
21#	53701-03	SCREW, M6 X 1, 20MM	2	
22	1000-124	CARRYING STRAP KIT W/ HARDWARE.....	1.....	INCLUDES ITEMS W/#

VIBRATOR MOTOR ASSY.

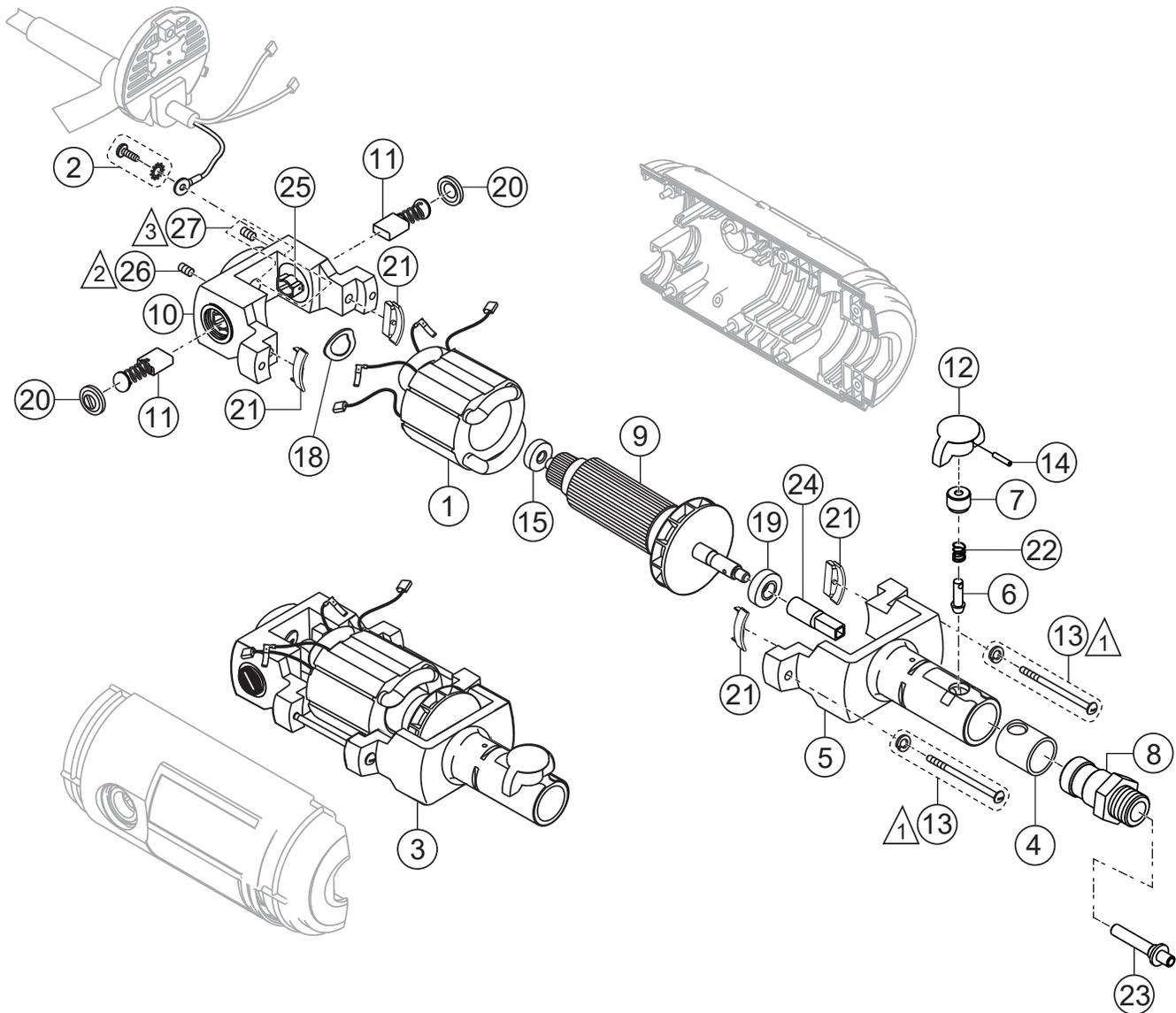

NOTES:

- ① TORQUE TO 50-70 IN.-LBS. (5.65 N-m to 7.91 N-m)
- ② TORQUE TO 4-6 IN.-LBS. (.5 N-m to .7 N-m).
TO REMOVE SET SCREW, USE A 3/32 ALLEN WRENCH.
WHEN REPLACING SET SCREW, ADD 2-3 DROPS OF
#680 LOCTITE (GREEN) IN SET SCREW HOLE.
- ③ INCLUDE ITEMS 25 AND 26.

VIBRATOR MOTOR ASSY.

<u>NO.</u>	<u>PART NO.</u>	<u>PART NAME</u>	<u>QTY.</u>	<u>REMARKS</u>
1	3061-013	FIELD ASSY., 1HP 115V CV1A	1	
1	3061-014	FIELD ASSY., 2HP 115V CV2A	1	
1	3063-014	FIELD ASSY., 2HP 230V CV2B	1	
1	3061-015	FIELD ASSY., 3HP 115V CV3A	1	
1	3063-015	FIELD ASSY., 3HP 230V CV3B	1	
2	1000-252	GROUND SCREW W/ WASHER	1	
3	1000-101	MOTOR ASSY., 1HP 115V CV1A	1	
3	1000-102	MOTOR ASSY., 2HP 115V CV2A	1	
3	1000-103	MOTOR ASSY., 2HP 230V CV2B	1	
3	1000-104	MOTOR ASSY., 3HP 115V CV3A	1	
3	1000-105	MOTOR ASSY., 3HP 230V CV3B	1	
4	6100-003	BUSHING, BRONZE WEAR	1	
5	1000-115	END BELL ASSY., OUTPUT 1HP	1	
5	8100-033	END BELL ASSY., OUTPUT 2HP	1	
5	8100-032	END BELL ASSY., OUTPUT 3HP	1	
6	7200-001	LOCK PIN, QUICK DISCONNECT	1	
7	90004-07	HOUSING, SPRING	1	
8	90004-05	SHAFT COUPLING, QD 314V CV1A	1	
9	8001-045	ARMATURE AND BEARING ASSY., 1HP 115V.....1.....	1	CV1A
9	8001-044	ARMATURE AND BEARING ASSY., 2HP 115V.....1.....	1	CV2A
9	8001-047	ARMATURE AND BEARING ASSY., 2HP 230V.....1.....	1	CV2B
9	8001-043	ARMATURE AND BEARING ASSY., 3HP 115V.....1.....	1	CV3A
9	8001-046	ARMATURE AND BEARING ASSY., 3HP 230V.....1.....	1	CV3B
10	8005-055	END BELL ASSY., COMM.	1	
11	43000-32	BRUSH ASSY., CARBON	2	
12	50125-04	KNOB, PLASTIC QUICK DISCONNECT	1	
13	1000-250	MOTOR SCREW W/WASHER	2	
14	53002-09	PIN, SLOTTED PIN 5/32 X 1	1	
15	55005-03	BEARING, REAR	1	
18	56000-06	WAVE SPRING	1	
19	55008-03	BEARING, FRONT	1	
20	1000-091	CAP, BRUSH	2	
21	59001-11	INSULATOR, PLASTIC FIELD	4	
22	59999-08	SPRING, COMPRESSION	1	
23	90004-03	SHAFT, SPINDLE 314V CV1A	1	
24	90004-02	DRIVE COUPLER, QUICK DISCONNECT	1	
25#	57000-15	BRUSH HOLDER	2	
26#	53051-01	BRUSH HOLDER SET SCREW #10-32 X .375	2	
27	1000-249	BRUSH HOLDER W/ SET SCREW.....2.....	2	INCLUDES ITEMS W/#

OPERATION AND PARTS MANUAL

HERE'S HOW TO GET HELP

PLEASE HAVE THE MODEL AND SERIAL
NUMBER ON-HAND WHEN CALLING

UNITED STATES

Multiquip Inc.

(310) 537- 3700
6141 Katella Avenue Suite 200
Cypress, CA 90630
E-MAIL: mq@multiquip.com
WEBSITE: www.multiquip.com

CANADA

Multiquip

(450) 625-2244
4110 Industriel Boul.
Laval, Quebec, Canada H7L 6V3
E-MAIL: infocanada@multiquip.com

UNITED KINGDOM

Multiquip (UK) Limited Head Office

0161 339 2223
Unit 2, Northpoint Industrial Estate,
Globe Lane,
Dukinfield, Cheshire SK16 4UJ
E-MAIL: sales@multiquip.co.uk

© COPYRIGHT 2021, MULTIQUIP INC.

Multiquip Inc, the MQ logo are registered trademarks of Multiquip Inc. and may not be used, reproduced, or altered without written permission. All other trademarks are the property of their respective owners and used with permission.

This manual MUST accompany the equipment at all times. This manual is considered a permanent part of the equipment and should remain with the unit if resold.

The information and specifications included in this publication were in effect at the time of approval for printing. Illustrations, descriptions, references and technical data contained in this manual are for guidance only and may not be considered as binding. Multiquip Inc. reserves the right to discontinue or change specifications, design or the information published in this publication at any time without notice and without incurring any obligations.

Your Local Dealer is:

