

Silver-Line SL-7 Operator's Manual

Read This Book

This book has important information for the use and safe operation of this machine. Failure to read this book prior to operating or attempting any service or maintenance procedure for your Silver-Line machine could result in injury to you or to other personnel; damage to the machine or to other property could occur as well. You must have training in the operation of this machine before using it. If you or your operator(s) cannot read English, have this manual explained fully before attempting to operate this machine.

All directions given in this book are seen from operator's position at the rear of the machine.

Essex Silver-Line Corporation, 1118 Lakeview Ave. PO Box 40, Dracut, MA 01826
www.essex-silver-line.com

The Silver-Line SL-7 Floor Edger (Suggestions for Care & Operation...Parts List)

Introducing:

Your new Silver-Line SL-7 edger is the easiest and fastest cutting edger available to the professional and rental trades. It is complete and ready to operate having been adjusted and thoroughly tested at the factory. The following suggestions will assure your getting the long life and excellent performance engineered into each and every machine.

Inspect:

Check the shipping cartons for any signs of damage and inspect the machine and its parts for any possible damage.

Assemble:

Assemble the machine by attaching the dust tube elbow to the back of the edger with the screws provided. Place the bag over the support and secure it tightly with the Velcro strap to the neck of the dust tube. Please be advised that a new bag will not fully expand until it is fully cured. The curing process will be completed with use.

Voltage:

The voltage is indicated on the nameplate. Lay the edger on its side, be sure the switch is turned OFF and plug into the proper current. Use of current other than specified will damage the motor. When additional extension cords are required use only 12/3 heavy-duty cord.

Starting:

To start your new edger just tilt it back so the disc is off the floor and turn switch on. Lower the edger onto work carefully keeping machine in motion while it is running. The weight of the SL-7 is precisely balanced to produce maximum results without additional pressure for every scope of work.

Lubrication: **Note: Your SL-7 is completely lubricated and ready to use when shipped from the factory!**

The ball bearings used in the production of this edger are sealed and no further attention is required for their life. The gears are made of a special alloy; heat-treated and under normal service *require lubrication about four times a year*. To lubricate the SL-7 remove the grease plug and put approximately 1/3 of a one shot tube of grease (C7-84) into the hole. Turn the machine on and let the extra grease come back out the hole. If the machine does not kick any grease out add more grease. Repeat this process until the edger is fully greased, reinstall the plug and clean any grease on the machine.

Dust Collecting:

The dust collection system will be most efficient when the bag is emptied when it is 1/3 to 1/2 full. Remember to remove all sawdust from the house. Paper or any foreign obstruction can be easily removed by taking the dust tube off.

Disc Pad:

The disc pad installed on your new SL-7 edger has been aligned in the factory to make the best possible cut and get the best dust pick up. Adjusting the cut on your edger is easy using a set of castor adjusting bars (C7-87). From the operators position, the space between the caster bracket and bearing shoulder should be approximately 1/4" on the left and 3/16" on the right.

Motor:

The motor commutator may be smoothed if it becomes necessary. Remove the two screws from the front cover tag and insert the proper stone through the slot you exposed. Replace the cover for proper ventilation.

Disc Guard:

The disc guard on the SL-7 should move freely enabling the user to sand upto baseboards and edges safely. Dust and dirt may effect its movement and you clean it out periodically. For cleaning remove the disc pad, disc guard ring and the disc guard. Blow out dust and dirt, dry clean only, do not use lubricant. Reinstall the parts you removed.

Wiring: Please check the wiring and cords before using or renting this machine

Questions: Please call us @ 1 800 451-5560 or email our website www.essex-silver-line.com if we can answer any questions.

Warranty: Please fill out the enclosed warranty card, tear at the perforation and mail the proper section to our Dracut, MA plant.



SL-7 Floor Edger Parts Price List

Part #	Description	Cost	Part #	Description	Cost
C70	SL-7 Carrying Box (Wood)	\$60.00	C7-28	Wheel Bracket	\$32.90
C71	Motor Frame	\$177.10	C728B4	Bumper	
C72	Gear Housing	\$151.80	C728D	Dustless Bracket	\$42.15
C72D	Gear Housing (Dustless)	\$156.80	C728D-4	Glides (Dustless)	\$4.00
C72D2	Nylon Glide (Snap On)	\$0.00	C729	Nut-Lockout	\$0.70
C73	Gear Housing Cover	\$50.60	C730	Short Cord Assembly	\$23.40
C74	Motor Housing Cap	\$36.70	C730A	Short Cord Only	\$4.75
C75	Lamp Shield	\$22.75	C731	Cord Only (25')	\$24.05
C76R	Handle (Right)	\$39.20	C732	Male Twist Lock (3 Wire)	\$7.50
C76L	Handle (Left)	\$34.15	C733	Strain Reliever	\$6.35
C77	Dust Tube	\$44.30	C734	Lamp Socket	\$5.05
C77Y	Exhaust Tube (Dustless)	\$29.97	C735	Lamp	\$1.25
C78	Vacuum Fan	\$24.00	C735220	Lamp (220V)	\$4.25
C79	Baffle Plate	\$10.10	C736	Bag Support	\$8.75
C710	Gear (Large)	\$84.75	C736A	Strain Reliever	\$1.79
C711	Gear (Small)	\$30.35	C737	Collar	\$1.90
C712	Bearing Plate	\$30.35	C738	Dust Bag	\$13.80
C712A	Load Spring	\$1.90	C738R	Dust Bag (Reinforced)	\$14.80
C713	Screw (Nameplate)	\$0.40	C739	Screw (Motor Cap)	\$0.30
C716	Armature (115 Volt)	\$139.15	C740	Bearing #1 (Comm) 6201	\$8.85
C716220	220 Volt Armature	\$150.00	C741	Bearing #2 (Fan End) 6202	\$9.50
C716240	240 Volt (50Hz) Armature	\$150.00	C742	Grease Plug	\$3.15
C716A	Armature w/Baffle & Vacuum Fan	\$177.10	C743	Key (Small Gear)	\$0.90
C716B	Cooling Fan (Press On)	\$15.46	C744	Screw (Shield)	\$0.30
C716D	Spacer (Replaces Grease Slinger)	\$3.50	C745	Nut (Left Handed)	\$3.65
C717	Field	\$60.70	C746	Shield	\$12.65
C717A	Field (240V, 50hz)	\$65.70	C747	Screw (Baffle & Vent)	\$0.30
C717B	Field Clips	\$0.50	C748	Screw (Housing)	\$0.30
C718	Brush Holder	\$8.35	C749	Caster Assembly (Complete)	\$30.35
C719	Brush Cap	\$1.90	C749C1	Stem	\$3.60
C719A	Brush Cap (Old Style)	\$2.30	C750	Screw	\$0.30
C720	Brush	\$6.25	C751	Handle Screw & Washer	\$3.15
C721	Insulator (Not pictured, obsolete)	\$0.30	C760	Cord Complete	\$33.00
C722	Screw (Field)	\$0.60	C760220	Cord Complete (220v)	\$67.95
C723	Nameplate (Front)	\$2.30	C761	Bearing #3 (Upper Jackshaft) 6203	\$9.50
C724	Switch	\$13.80	C762	Jackshaft	\$46.45
C725	Screw (Lamp Socket)	\$0.30	C763	Key	\$0.90
C726	Spacer (New Style)	\$5.70	C764	Fiber Washer	\$0.30
C727	Ventura Plate	\$5.05	C765	Disc Guard Ring	\$24.65
	Essex Silver-Line Corporation			Toll Free 800 451-5560	
	1118 Lakeview Ave.			Fax (978) 957-6989	
	PO Box 40			Phone (978) 957-2116	

Dracut, MA 01826			www.essex-silver-line.com
Part #	Description	Cost	www.essex-silver-line.com
C766	Screw (Disc Guard)	\$0.30	
C767	Disc Guard	\$25.60	
C767B	1/2 Moon Baffle Plate	\$6.50	
C768	Disc Pad	\$67.85	
C768R	Disc Pad (Refurbished)	\$33.93	
C769	Paper Retaining Washer	\$3.60	
C770	Paper Retaining Bolt	\$2.35	
C771	Bearing #4 (Lower Jackshaft) 6204	\$8.85	
C772	Screw (Gear Cover)	\$0.30	
C773	Screw (Dust Tube)	\$0.30	
C774	Screw (Brush Holder)	\$0.30	
C775	Wrench Clip	\$3.15	
C776	Screw (Wrench Clip)	\$0.95	
C778	Wrench	\$10.10	
C779	Plug (Male Straight) #1447	\$7.00	
C780	Plug (Female Twistlok) #4729C	\$12.00	
C781	Nameplate (Top)	\$1.80	
C782	Disc Cutter (7")	\$60.70	
C782A	Cutter Blade	\$7.60	
C782B	Center Punch	\$5.70	
C782D2	Nylon Bar (2)	\$25.00	
C782D3	Threaded Nylon Washer	\$0.00	
C784	Grease (One Shot Tube)	\$3.80	
C785	Gear Housing Cover Remover	\$10.30	
C786	Disc Pad Remover	\$11.45	
C787	Caster Adjusting Bars	\$9.15	
C787A	Protective Screen	\$0.00	
C788	Clarke Disc Spacers	\$5.05	
C789	Clarke Edger Wrenches	\$11.40	
C790	Quarts Edger Grease	\$13.15	
C791	White Nylon Washers (Spacers)	\$0.10	
C792	Tool Repair Kit	\$29.95	
C793	Motor/Gear Housing Separator Tool	\$40.00	
ADP	American Disc Pad (B2)	\$67.85	
CB	Clarke Edger Bolts	\$2.35	
CP	Clarke Disc Pad	\$67.85	
CW	Clarke Edger Washers	\$3.60	



Silver-Line SL-7 Edger



SL-7 Floor Edger Parts Price List

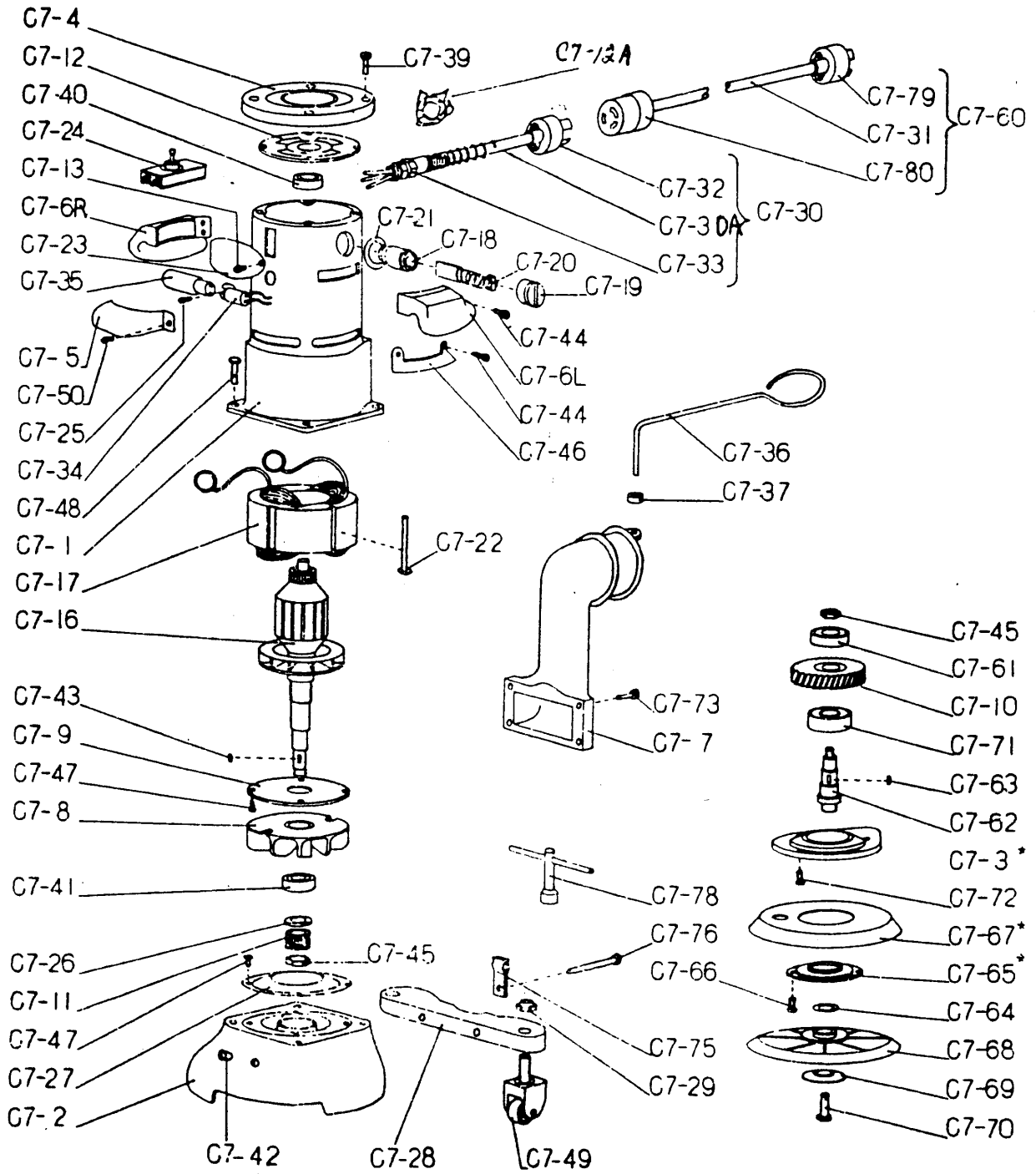

- C7-12A Load Spring.....1
- C7-30A Short Pigtail.....1

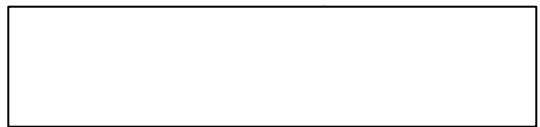

Simple Preventive Maintenance

Will save you money and keep your working equipment sound

Blow out the dust from you edger after every use. Make sure to blow out around the disc pad, guard, brushes and the hole for the paper retaining screw.

Grease you machine every 2 to 3 months depending upon usage.

Check motor brushes every three months the first year and keep the brush holder free from dust. Check brushes more often the 2nd year. Replace brushes when ¼" long.

Check the disc pad often for wear; replace it when worn, as it will save wear and tear on you machine.

Check center hole (jackshaft) on the disc pad for accumulation of dust and grit. **Do Not** let it build up in this hole. Clean it out so that you get full movement from the bolt. The disc washer should not move when holding paper.

Check you cable, electrical equipment, plug, etc. before sending it out. This saves you time, money and headaches.

Check dust bags for worn or torn spots. Keep the dust bag clean and in good condition.

Check dust collection; do not let it get blocked.

Check the casters on the SL-7, they are adjusted in the factory to make the machine cut correctly. You should keep the casters blown out so they move freely. The caster stems should be straight. If the stem is bent, try to straighten it, but you may need to replace the unit.

Service and repair notes for Whippet C7 & ESL SL-7 edgers:

Whippet edgers from serial #'s 1 to 661 do not have armatures or fields available.

Whippet and Silver-Line edgers with serial #'s from 662 to 1256 use the old style armatures and require a grease slinger (spacer). You may replace the old style armature and field with the present units. When you upgrade the grease slinger is no longer required.

Load spring part # C712A should be used with all edgers and fits on top of the bearing plate (C712), and over the top bearing.

The old style brush holder is no longer available. This used a brush ring and insulator (C721). Please identify style when ordering.

When ordering a disc guard please note which style you need, stationary or rotating. Your new parts list shows the rotating parts. *As of 01/2001* the stationary gear housing cover is not available, purchase a new gear housing cover and guard. At this time the stationary disc guard (C767A) is still available, when our supply is depleted this part will be discontinued.

Adjusting the Cut on the SL-7 Edger

- 1) Locate yourself behind the unit as if you were going to run it. The space between the bearing shoulder and caster bracket should be ¼" on the left and 3/16" on the right.
- 2) Caster adjusting bars (C787) can be used to check the spacing.
- 3) If your casters are not spaced correctly loosen the retaining nut and move the caster with a screwdriver. Check the spacing and tighten the nut when it is in the correct position.
- 4) The adjustments are easier to make when the edger is located on the edge of a table with the casters overhanging.
- 5) Run your new disc pad against a piece of 100 grit paper to remove high spots and rubber nubs that result from manufacturing. Run until the pad runs smooth, with no vibrati on.
- 6) Your edger should make a pie slice cut from twelve fifteen to one o'clock on the floor.

SL-7 Floor Edger

Repair/Maintenance

Instructions

1. Disc Pad Removal
2. Brush Replacement
3. Bearing Replacement
4. Adding Grease
5. Tap out Jackshaft for Bolt & Washer
6. Clean Armature Commutator

Before attempting any repairs on your Silver-Line SL-7 edger disconnect it from power. The tools referred to in these instructions are available from Essex Silver-Line Corporation, call us @ 800 451-5560 and ask for each tool separately or as a kit part # C7-92.

- 1) Disc pad Removal: *The disc pad is threaded onto the jackshaft in a clockwise motion!*
 - a) Remove dust tube exposing the vacuum fan on the armature. (4 screws) **(Fig. A)**
 - b) Turn edger upside down, resting on the flat top of the SL-7.
 - c) Block the fan with the handle of a hammer or screwdriver to stop the armature from moving.
 - d) Line up the bolts of the disc pad remover with the holes on the disc pad, and insert them into the disc pad.
 - e) Using a hammer, tap the disc pad remover counterclockwise to remove the old disc pad.
 - f) The disc pad should thread off the jackshaft.

*Note: The jackshaft has interior and exterior threads. The interior accepts the bolt and washer while the exterior threads are for the disc pad! **(Fig. B)***

- 2) Carbon Brush Replacement:
 - a) Remove brush caps using flathead screwdriver. Be careful not to damage the slots on the caps.
 - b) Remove the old brushes and blow out edger with compressed air. The brush holders should be blown out periodically as a part of maintenance.
 - c) Install the new brushes and reinstall the brush caps.
 - d) Run the unit to break in the new brushes.

- 3) Replacement of Bearings:
 - a) C7-40 (6201) *Top bearing*
 - i) Remove cover (C7-4) and load spring (C7-12a) (4 screws). Be careful to see how the load spring comes out of the machine so you can put it back in the proper position.
 - ii) Mark the top of the Bearing plate (C7-12) with a magic marker to show which side is top. Remove the bearing plate with a set of pullers.
 - iii) Remove the bearing with pullers.
 - iv) Tap a new bearing onto the armature (6201).
 - v) Reinstall the bearing plate, load spring, cover and screws.

- b) C7-41 (6202) *Located on the bottom of the armature, You must take the edger apart & remove the armature to replace this bearing.*
- i) Remove disc pad (See #1)
 - ii) Remove the disc guard ring (C7-65), and disc guard (C7-67) (5 screws)
 - iii) Remove the 6 flat head screws holding the gear housing cover (C7-3) in place.
 - iv) Using the gear housing cover remover (C7-85) pull the jackshaft, gears and gear housing cover out of the machine. **(Fig. C)** Remove the gear housing remover and tap the jackshaft out of the gear housing cover. **(Fig. D)**
 - v) Clean the grease from the base to avoid a mess.
 - vi) Turn the machine upright.
 - vii) Remove cover (C7-4) and load spring (C7-12a) (4 screws). Be careful to see how the load spring comes out of the machine so you can put it back in the proper position.
 - viii) Mark the top of the Bearing plate (C7-12) with a magic marker to show which side is top. Remove the bearing plate with a set of pullers.
 - ix) Remove four housing screws (C7-48) that hold the motor frame (C7-1) to the gear housing (C7-2).
 - x) Hold the motor frame on your hip with the lamp shield C7-5) facing out. Gently tap the gear housing away from the motor frame using a rubber mallet; rotate the housing as you hit it. The bearing at the base of the armature (C7-41) is seated in the gear housing, holding the armature in place.
 - xi) Once the base is remove, flip the motor frame upside down and remove four screws (C7-47) holding the baffle plate to the motor frame. Pull the armature out of the frame.
 - xii) Remove the LH nut (C7-45) on the end of the armature. *Note the shoulder of this nut has been machined, the small end face towards the gear.* Remove the small gear (C7-11), spacer (C7-26) and finally the bearing C7-41, (6202).
 - xiii) Replace the defective bearing and rebuild the armature.
 - xiv) Reinstall the armature into the motor frame and secure with the four bolts (C7-47).
 - xv) Line up the bearing (C7-41) with the bearing seat located in the gear housing (C7-2), tap the top bearing (C7-40) straight down so the bearing is lowered into the seat. Line up the holes in the motor frame and gear housing and reattach with the bolts (C7-48).
 - xvi) Turn the unit upside down, and grease the gear housing, small gear and large gear.
 - xvii) Line the jackshaft up with the gear housing and mesh the large and small gear teeth. Gently tap the jackshaft back into the gear housing, allowing bearing #3 (C7-61) to be inserted into its seat. The jackshaft will be install to the correct depth when the teeth of the two gears are at the same height.
 - xviii) Line up the gear housing cover with the gear housing and bearing #4 (C7-71) and tap it back in place. You may want to use a bolt to keep the cover lined up with the holes. Screw the bolts back into the cover.
 - xix) Flip the machine over and reinstall the bearing plate, load spring and Cover.
 - xx) Flip the machine over again, resting on the cover (C7-4) and reinstall the disc guard, disc guard retainer and disc pad.
- c) C7-61 (6203) & C7-71 (6204) *Located on the jackshaft.*
- i) Repeats steps 1-4 for replacing C7-41.
 - ii) Remove the LH nut from the jackshaft.
 - iii) Gently tap or press the jackshaft through C7-61 (6203) bearing.
 - iv) Remove large gear (C7-10) and key. Clean gear and check for wear.

- v) Gently tap or press the jackshaft through C7-71 (6204) bearing.
 - vi) Rebuild jackshaft assembly with new bearings. Replace gear if necessary. *Note: Check interior threads on jackshaft for excessive wear and replace it before you rebuild it!*
 - vii) Repeat steps 16-18 for replacing C7-41.
 - viii) Reinstall the disc guard, disc guard retainer and disc pad.
- 4) Add Grease:
- a) Remove grease plug (C7-42) and clean out hole in center.
 - b) Insert one shot tube of grease into hole and squeeze a small amount into edger.
 - c) Connect the edger to power, hold it so the disc pad is off the floor and turn on the edger. Let the edger spread the grease over and between the gears.
 - d) Shut down the edger and add a little grease. Turn on the edger, repeating until the edger pushes grease out the hole.
 - e) Clean the grease off the edger and replace the grease plug (C7-42).
- 5) Tap out Jackshaft for Bolt & Washer:
- a) Turn the edger over and set it on its top.
 - b) Using compressed air, blow out jackshaft
 - c) Using a small bit, drill out built up grit and paper at the bottom of jackshaft. Drill straight down to avoid the threaded sides of the interior jackshaft.
 - d) Repeat b & c as needed.
 - e) Tap the jackshaft with a 5/16-18" Tap.
 - f) Test depth with new bolt (C7-70) from Essex Silver-Line Corporation.
- 6) Clean Armature Commutator:
- a) Remove disc pad, disc guard and disc guard retainer.
 - b) Remove motor cap and load spring.
 - c) Secure bearing plate (C7-12) with one screw.
 - d) Turn on edger.
 - e) Using commutator stone, clean black carbon residue off the commutator through the holes in the bearing plate. **(Fig. E)**
 - f) Clean until proper copper color shows.
 - g) Reassemble the machine.

Problem: Edger seems to be running loud?

Answer: Grease gears as needed.

Problem: Squealing noise!

Solution: Check and replace bearings as needed.

1st remove the dust tube and look down into bearing seat holding C7-41. If you see an accumulation of sawdust than the bearing probably needs to be replaced.

2nd, if bottom bearing C7-41 looks clean, check the top bearing C7-40 by removing the cap, load spring and bearing plate and test the bearing for wear.

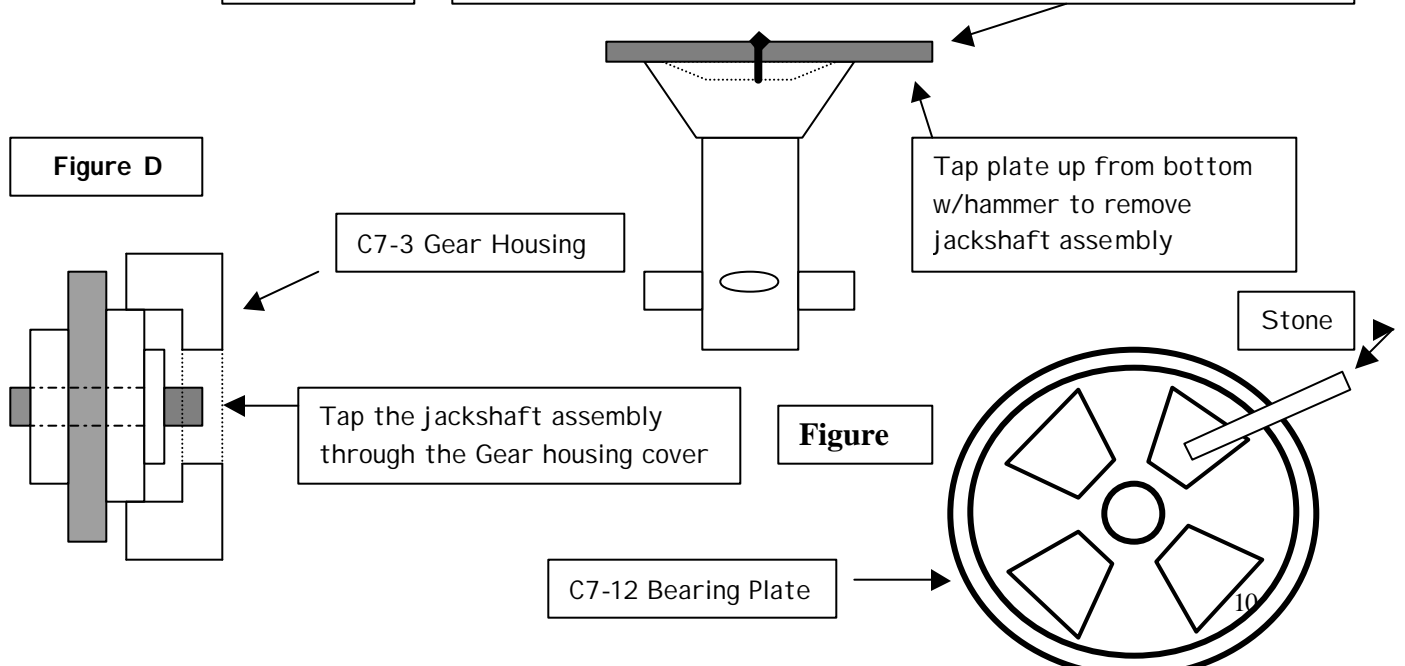
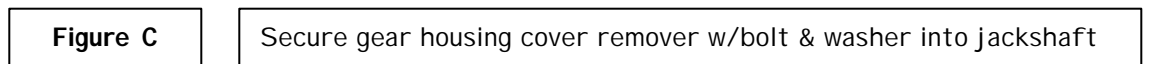
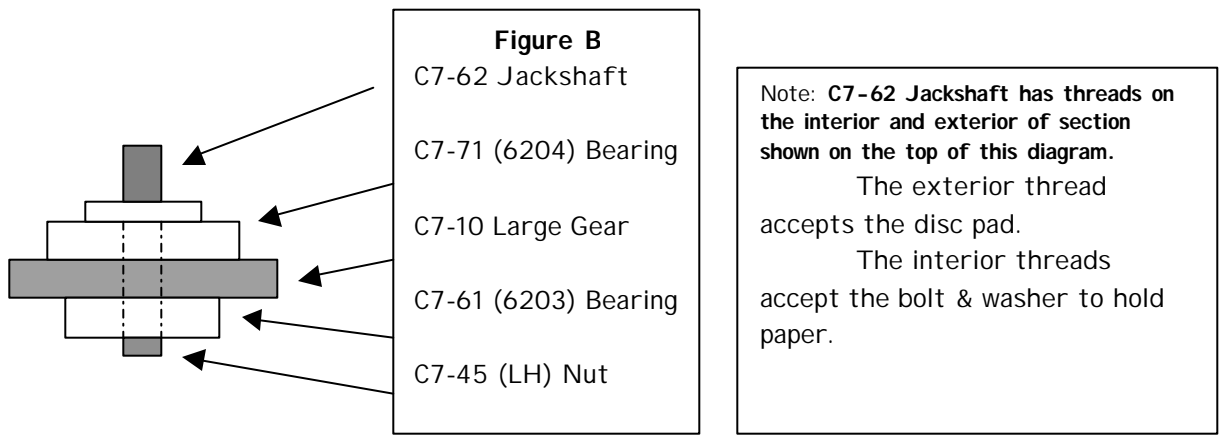
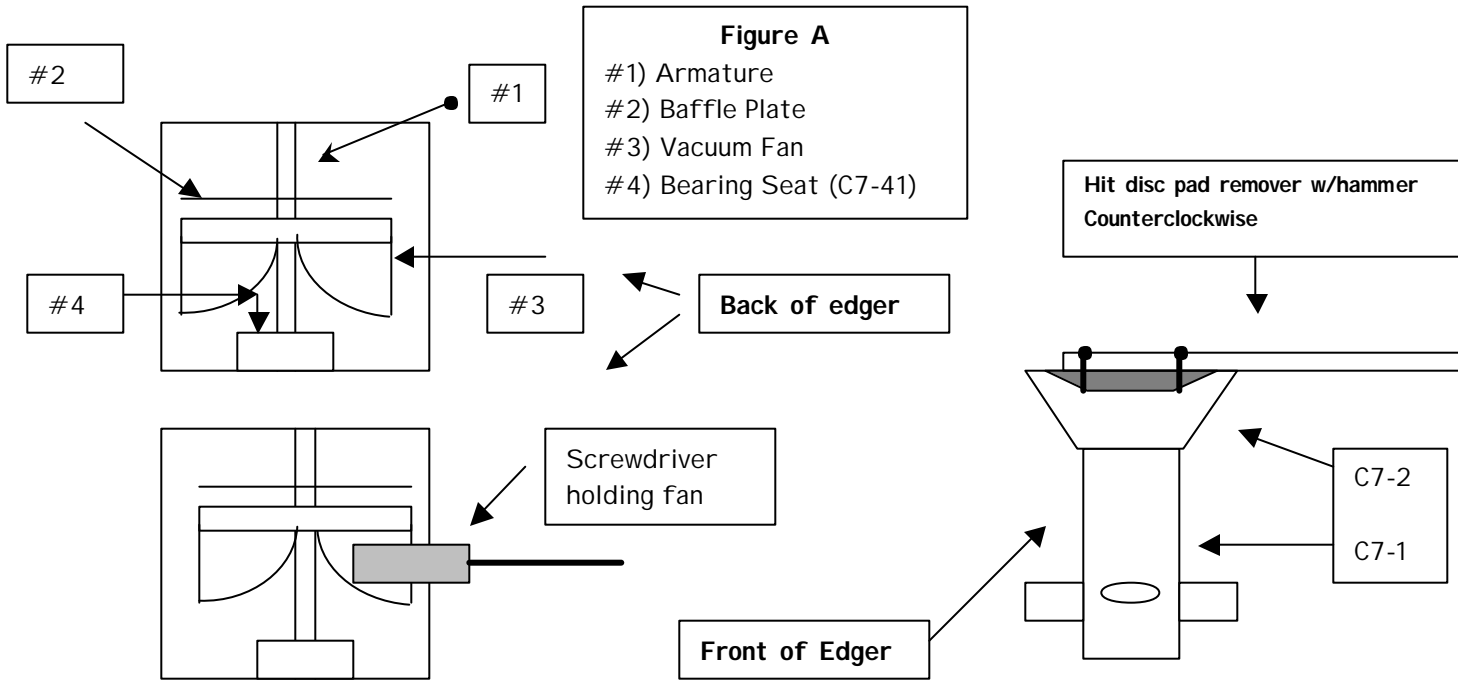

Proper Application & Use of Silver-Line Abrasives

12, 16, 20* grit Sheets & Discs

For removing old surface coatings and leveling uneven floors

36, 40* grit Sheets & Discs

For intermediate sanding of floors following rough sanding.

For initial sanding of moderately worn floors

60*, 80, 100* grit Sheets & Discs

For finish sanding of all floors prior to applying new coatings

For removing light scratches, sanding marks and minor surface damage

60, 80, 100, 120, 150 & 180 grit Sandscreens

For removing fine scratch marks prior to applying new coatings

For light sanding between surface coatings

*Indicates most popular rental grits for sanding floors. 60 & 100 grit should be used in succession for proper finish. Never skip more than two grits when sanding a floor.

Example: Do not jump from 36 grit to 80 or 100 grit

Always start your sanding project with the highest possible grit that will cut and level your floor. If the grit will not cut the finish or level the floor, go down one grit size to complete the cut!

White* Thick Nylon Pads

Buffing, for polishing floors where highest luster is desired

Green Thick Nylon Pads

Scrubbing, for general duty scrubbing and spot removal on floors

Black Thick Nylon Pads

Stripping, for heavy duty wet stripping of floors

** White pads should be used under the padlocks when using sandscreens on rotary and orbital polishers. They are used for driving sandpaper on Orbital Polishers.*

Wood Floor Refinishing *The Silver-Line Way*

(Visit our website www.essex-silver-line.com under consumer tips for complete information)

Job Preparation:

Remove the furniture, wall hangings, etc. Clear the room out!
Remove the old carpet, carpet pad and carpet strip (where necessary)
Locate & Reserve *only* Silver-Line Sanders & Edgers from your local rental store
Watch the Silver-Line "How to" Video

Inspect the floor for and remove...
Staples from the carpet pad
Nails from the tackstrip
Nails protruding from the floor (countersink these nails)

***Make sure you are very diligent when completing this task, protect the rental machine!
You may be liable for damage to the drum and disc pad on the rental equipment!***

Protect the rest of your house from sawdust, sweep the floor and vacuum, and pick up the equipment!

Sanding the Floor:

What are you trying to accomplish during this project? First, you want to level the floor, and remove the old finish. The remaining cuts or passes are to remove the scratch marks made by the previous cuts. Do not skip too many grits when sanding the floor, as the finer grits may not be able to remove the heavier scratches.

Start the process with the highest grit possible to complete the first cut, leveling and removing the finish. If a 36 or 40 grit will accomplish the task, then do not use 20 grit or heavier. If it seems to be taking too long, drop down and use the heavier grit. By doing this you will probably save time.

Break the room down into two sections, 1/3 to 2/3 and sand the larger area first. Complete the 2/3 section and turn around to sand the remaining 1/3. *Do this with all the grits.* Offset where you stop and start the sanding so you do not end up with a line across your floor at the end of the project.

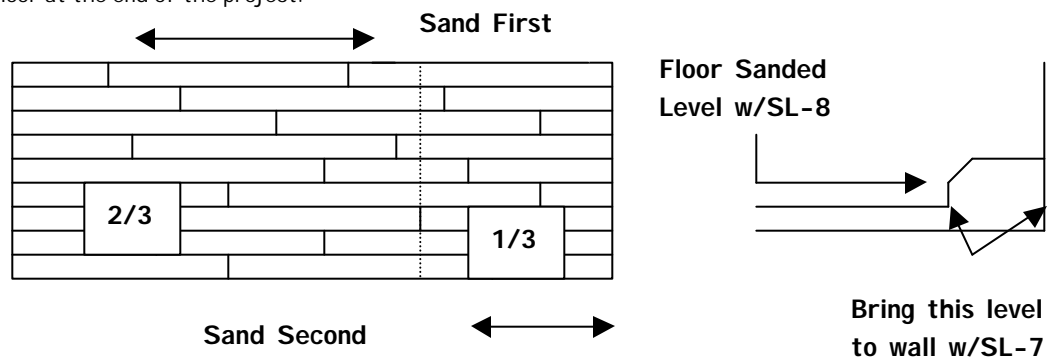

Use the SL-8 sander for the main section of the floor and then follow with the SL-7 edger. This method will allow you to set the level you want in the main section of the floor and then bring it out to the edge of the room with the SL-7.

To use the Silver-Line SL-8 correctly, you sand forward and backward on the same line with the SL-8 sander. Be sure to lift up on the handle with enough force to keep the drum pressure constant on the floor. Feather the sander so the drum comes off the floor while moving forward or backward when you reach an area that you need to stop.

The following grits are recommended for a professional looking sanding job. Again, you want to start with the least aggressive grit to complete the leveling and finish removal and proceed up through the grits.

20, 36 or 40, 60 and finally 100

Note: If you trip a breaker or blow fuse, turn off the equipment off, then reset the breaker or replace the fuse.

Note: Remove all sawdust from the house as you empty the dust bags. Empty your sander bags when they are ½ full, this will help with the dust pick up. Sawdust can be flammable and you do not want it in your house.

Note: When using the SL-7 edger, sand from right to left and let the edger do the work. A properly aligned edger, with a disc pad in good condition will function well without the user exerting additional pressure. Let the edger do the work; don't put extra pressure on the machine. Work at a pace you are comfortable with, and take frequent rests.

If the cutting action of your sander seems to slow or diminish, it is probably time to change the sandpaper. In an effort to save money, don't try to extend the life of the paper, replace it as needed. If you skimp on the amount of paper you use on this project it will affect the end result. Don't look at the cost at the time of sanding, but rather over the life of the floor. Replace abrasives to get the same type of cut across the floor.

After you sand the floor with the SL-8 & SL-7 it is time to scrape corners, door jambs, etc. Use our 12 wood handle scraper with a 1" Red Devil blade, available from the rental store, to accomplish this task. Hand sand the areas you scraped.

If you have areas such as baseboard heat, radiators or toekicks that could not be reached by the SL-7, use the Silver-Line U2 underradiator sander to clean up these areas. It uses 5" PSA discs and is also available at the rental store.

When your done sanding your floor return your sanders to the rental store. Remember to return the cords, wrenches, bags and unused supplies.

Note: After sanding you should screen the floor before you apply any finish or stain to achieve the best possible finish. A professional floor sander will screen his work; spend the time and money to screen your floor.

Essex Silver-Line Corporation
PO Box 40
1118 Lakeview Ave.
Dracut, MA 01826
(978) 957-2116, Fax (978) 957-6989
Toll Free 800 451-5560

www.essex-silver-line.com

Essex Silver-Line Corporation

Limited One Year Warranty

Essex Silver-Line Corporation warrants the floor sanding equipment for a period of one year from the date of original purchase. We will repair or replace at our option, any part or parts of the products under this warranty which examination proves to be defective in workmanship or materials during the warranty period. For repair, return machine or parts to Essex Silver-Line Corporation transportation prepaid. This warranty does not apply to repair or replacement required due to misuse, abuse, normal wear and tear and/or repairs attempted or made by other than our service center. For the purpose of this warranty, damage resulting from accident, use of defective or inadequate wiring at the installation in which used, improper cleaning or operation, fire, floods or act of God, are not covered. No other warranty implied or expressed is offered and under no circumstances shall Essex Silver-Line Corporation be liable for an incidental or consequential damage.

Essex Silver-Line Corporation
PO Box 40
1118 Lakeview Ave
Dracut, MA 01826
(978) 957-2116, Fax (978) 957-6989
Toll Free 800 451-5560
www.essex-silver-line.com

